

Performance of Induction Motor fed by Sine Pulse Width Modulated Inverter using XILINX

Ravi Prakash¹, Rishi Kumar Singh², Rajeev Ranjan Kumar³

¹Ravi Prakash, Department of Electrical Engineering, Maulana Azad National Institute of Technology Bhopal, MP, India

²Professor, Rishi Kumar Singh, Department of Electrical Engineering, Maulana Azad National Institute of Technology Bhopal, MP, India

³MTech Scholar, Rajeev Ranjan Kumar, Department of Energy Center, Maulana Azad National Institute of Technology Bhopal, MP, India

Abstract - In this paper performance characteristic of two levels inverter fed induction motor drive is analyzed. Open loop control of induction motor (IM) is used in this inverter scheme. The analysis has been done in terms of THD in their line current. Steady state response of speed, current and torque in induction motor are also obtained using this scheme. Model is developed for SPWM inverter fed induction motor using Xilinx.

Keywords- Induction Motor (IM), Sine pulse width modulation (SPWM), Field Programmable Gate Array (FPGA), Xilinx

loop system [2]. The controlling waveform is generated by comparing sinusoidal and triangular waveform using Xilinx block set. By using suitable value of (Frequency modulation index) m_f and (Amplitude modulation index) m_a switching losses and conduction losses can be limited.

2. SPWM INVERTER TOPOLOGY

Here unipolar sine PWM technique is used, in which the voltage across the switch is equal to dc link voltage and maximum order harmonic is $m_f \pm 2$, $2m_f \pm 1$. So filter requirement is reduced which is the main advantage of PWM. Also for low values of m_f , to avoid non integer harmonic, synchronized PWM should be used and m_f should be an odd integer. To cancel out most dominant harmonic in the line to line voltage, m_f should be multiple of 3. From the lower switching losses point of view, used value of m_f is 15, and for under modulation, m_a is 0.8.

Here in the PWM generation by XILINX [Fig.1], we use basic formulae:

Time period of wave = Explicit period * Count to value

Following are the values taken in Xilinx block sets for PWM generation.

FPGA clock period = 10 nsec

Simulink system period = 1/345600

Explicit period for triangular wave = 1/345600

1. INTRODUCTION

Induction Motor is being widely used in industrial and domestic purposes. Due to easy maintenance and robustness, three phase induction motor is now being used in vehicles also. Three phase induction motor is an AC machine which runs at variable speed. To produce good speed response and less torque ripple these motors require good quality AC input [1].

Pulse width modulated voltage source inverter fed drives are preferred in industries for variable speed drives. Among the various pulse width modulation (PWM) schemes, sinusoidal pulse width modulation (SPWM) method is the most popular scheme employed in many applications.

Microprocessor based controllers are more economical, but often face difficulties in dealing with control systems that require high processing and input/output handling speeds. Rapid advances in digital technologies have given designers the option of implementing a controller on a variety of Programmable Logic Device (PLD), Field Programmable Gate Array (FPGA), etc. FPGA is suitable for fast implementation controller and can be programmed to do any type of digital functions.

In this paper Induction Motor is controlled using Xilinx block set because its hardware implementation is unconstrained [3]. Performance of induction motor is observed with SPWM inverter. Here in the pulse width modulation, motor is controlled using six switches in open

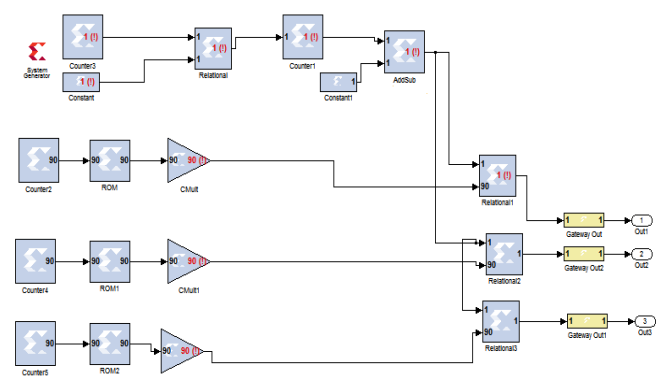

Fig.1 Generation of switching waveform for PWM using Xilinx

Explicit period for sine wave = 1/3480

Figure 2 shows the generation of PWM signals by comparing sine wave with triangular wave. Figure 3 shows complete block diagram of SPWM fed induction motor employing second order low pass filter with following parameters.

(Damping factor) $\xi = .707$

(Cutoff frequency) $\omega = 2\pi * 300$ radian/sec

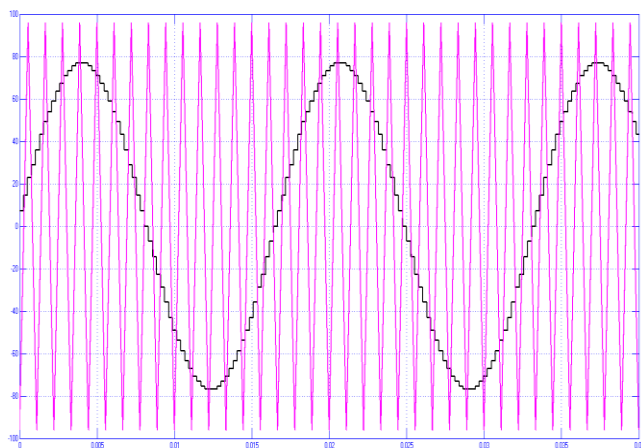

Fig.2 Comparison of sinusoidal and triangular waveform using Xilinx

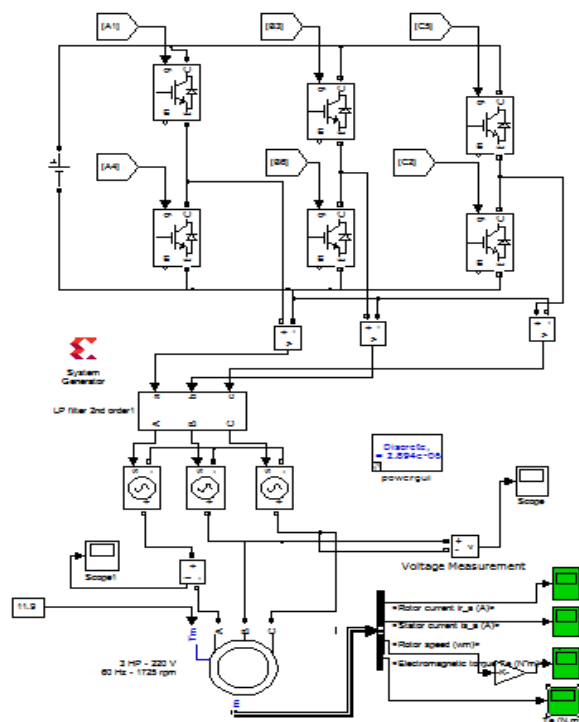

Fig. 3 Block diagram of PWM inverter fed induction motor

3. SIMULATION AND RESULTS

The figure 4 below shows the THD of line current of PWM fed induction motor. In this case second order low pass filter is used. It has been seen that for a damping factor ($\xi = .707$), and for obtaining the THD of line current less than 5%, cutoff frequency of the filter is 300 Hz.

In the PWM technique, 6 switches are used and all switches are working at 900 Hz. Here, only one DC bus of 450 volts is used.

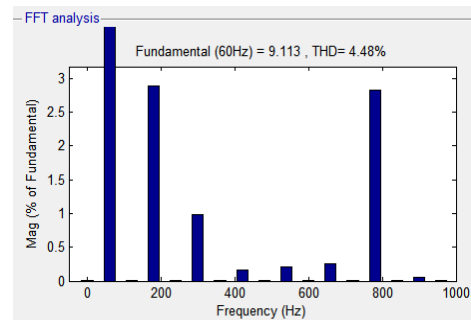

Fig.4 FFT Analysis of line current of PWM fed induction motor

Simulation for the open loop control of induction motor is performed using Xilinx. Parameters of induction motor are shown in table I. Simulation results are obtained and the performance characteristics of induction motor given in Fig.5 to Fig.7. Each characteristic is plotted with respect to time. Also fundamental component of output voltage for PWM fed induction motor is 220.9 volts and all the characteristics are obtained for following parameters of filter.

TABLE I: Specifications of motor

Parameters	Value
Power Rating	3 Hp
Line to line voltage	220 volts
Rotor type	Squirrel cage
Frequency	60 Hz
Rated Speed	1725 rpm
Stator resistance and Inductance [Rs(ohm) Ls(H)]:	[0.435, 2*2.0e-3]
Rotor resistance and	[0.816, 2.0e-3]

inductance [R_r' (ohm) L_r' (H)]:	
Mutual inductance L_m (H):	69.31e-3
Inertia, friction factor, pole pairs [J (kg.m ²) F (N.m.s) p ()]	[0.089, 0, 2]

Damping factor ($\xi = .707$)

(Cutoff frequency) $\omega = 2\pi * 300$ radian/sec for both PWM and MLI fed induction motor.

Figure 5 shows the complete torque characteristics for given schemes. It has been seen that steady state torque in both PWM fed induction motor reached at (t=0.8 second). Steady state torque ripple in case of PWM fed induction motor is also less. The upper and lower limit of steady state torque is nearly in between 11.1 Nm to 13.1 Nm for a PWM, when load torque is 11.9 Nm. Maximum torque (T_{max}) occurs before steady state reached is 89 Nm in case of PWM fed induction motor.

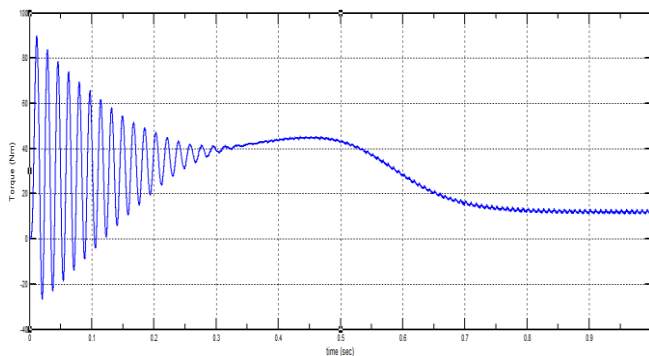

Fig.5 Complete torque characteristic of PWM fed induction motor

Figure 6 shows the complete speed vs. time characteristics, in which steady speed reached at (t=0.8 second) in case of PWM fed induction motor. The pulsation of steady state speed of PWM fed induction motor is in between 1725.52 rpm and 1725.34 rpm, which is very less.

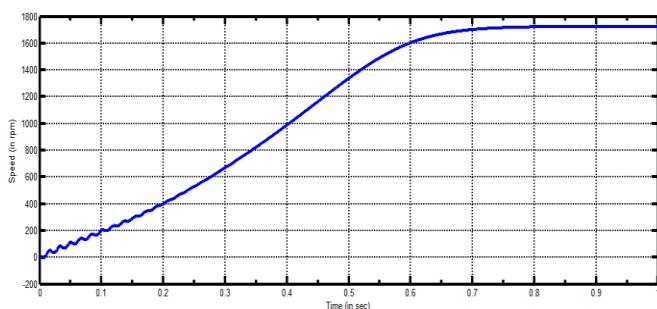
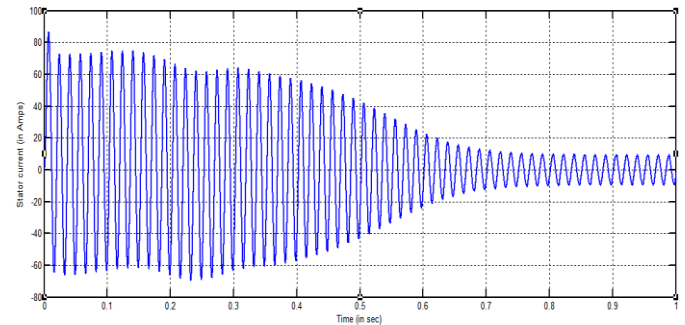
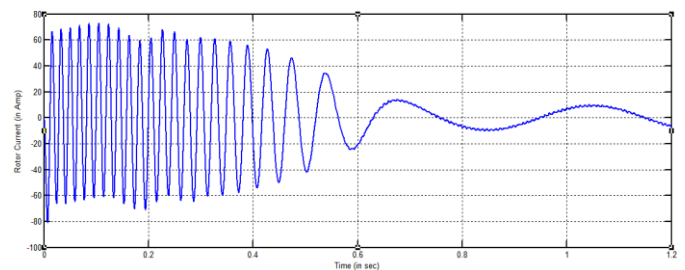

Fig.6 Complete speed characteristic of PWM fed induction motor

Figure 7 shows stator and rotor current characteristics of induction motor this scheme. Here, maximum value of starting line current is about 87 Amps. Maximum value of steady state line current in case of PWM is 9.113 Amps.



(a)



(b)

Fig.7(a) Stator current characteristic (b) Rotor current characteristic of PWM fed Induction motor

TABLE II: Comparison of various parameters of PWM fed induction motor for different values of damping factor (ξ) of filter

Damping factor (ξ)	Fundamental current (Amps)	Current THD	Fundamental Voltage (Volts)	Voltage THD	Speed (rpm)
0.5	6.325	5.25%	225.4	5.16%	1728
0.6	6.375	4.86%	223.4	5.04%	1727
0.707	6.452	4.48%	220.9	4.92%	1725
0.8	6.512	4.19%	218.4	4.81%	1723
0.9	6.591	3.91%	215.6	4.71%	1721

4. CONCLUSION

In this paper firstly three phase induction motor is simulated in open loop control on MATLAB/Xilinx by PWM, then characteristics of various parameters are obtained. It is observed that in PWM only six switches are

used. Without any filter, current THD in PWM fed induction motor is 29.95%. Due to which, steady state speed and torque pulsation is slightly more in PWM without any filter.

By using the filter, the given PWM topology with Xilinx block set limits the THD of line current and line voltage below 5% for a damping factor (ξ) equal to 0.707. Also Line Current THD and Line voltage THD of this scheme can be decreased to some extent by increasing the value of damping factor (ξ) as shown in table II. The fluctuations in speed of this scheme is also very less.

REFERENCES

- [1] Reddy M.H.V and Jegathesan V, "Open loop V/f control of induction motor based on hybrid PWM with reduced torque ripple," *International Conference on Emerging Trends in Electrical and Computer Technology*, pp.331-336, March 2011.
- [2] Arulmozhiyal R., Baskaran, K, Devarajan N and Kanagaraj J, "Space Vector Pulse Width Modulation Based Induction Motor Speed Control Using FPGA," *International Conference on Emerging Trends in Engineering and Technology*, pp.742-747, Dec 2009
- [3] Nekoei F, Kaviani, Y.S and Mahani A, "Three-phase induction motor drive by FPGA," *Iranian Conference on Electrical Engineering*, pp.1-6, May 2011.
- [4] Jianye Rao and Yongdong Li, "Sensor-less Drive of Induction Motor Based on A New Hybrid Cascaded Multilevel Inverter," *IEEE Applied Power Electronics Conference and Exposition*, 2009, pp.1819-1823, Feb. 2009
- [5] Elena Villanueva, Pablo Correa and Mario Pacas, "Control of a Single-Phase Cascaded H-Bridge Multilevel Inverter for Grid-Connected Photovoltaic Systems," *IEEE Transactions on Industrial Electronics*, Vol. 56, No. 11, NOVEMBER 2009
- [6] Verma V and Kumar A, "Power balanced cascaded multilevel inverter fed scalar controlled induction motor pump sourced from photovoltaic source," *IEEE International Conference on Power Electronics, Drives and Energy Systems*, 2012, pp.1-6, Dec. 2012
- [7] C. Bowen; Z. Jihua; R. Zhang; "Modeling and simulation of permanent magnet synchronous motor drives", *Electrical Machines and Systems*, ICEMS 2001, Vol. 2, 18- 20 Aug. 2001, pp. 905 – 908.
- [8] N. Urasaki; T. Senjyu; K Uezato, "An Accurate Modeling for Permanent Magnet Synchronous Motor Drives", *Applied Power Electronics Conference and Exposition*, APEC 2000, Vol. 1, 6-10 Feb. 2000, pp:387 – 392.
- [9] F. Blaabjerg, J.K. Pedersen, P. Thøgersen, "Improved modulation techniques for PWM-VSI drives", *IEEE Transactions on Industrial Electronics*, Feb. 1997, Vol. 44, pp. 87 – 95
- [10] F. Blaschke, "The principle of field-orientation as applied to the Transvector closedloop control system for rotating-field machines", in *Siemens Review* 34, 1972, pp.217- 220.
- [11] M.N. Uddin, T.S. Radwan, G.H. George, M.A. Rahman, "Performance of current controllers for VSI-fed IPMSM drive", *IEEE Transactions on Industry Applications*, Volume 36, Issue 6, Nov.-Dec. 2000 Page(s):1531 – 1538.