

REMOTE VIDEO MONITORING SYSTEM USING S3C2440 and GPRS

Mrs. S. N. Kale ¹, Mr. R. D. Patil ²

¹ME Electronics, Electronics Engg Department, PVPIT, Budhgaon, Maharashtra, India

²Associate Professor, Electronics Engg Department, PVPIT, Budhgaon, Maharashtra, India

Abstract: In This paper, friendly ARM9 board support package (BSP) S3C2440 is used for video monitoring remotely. This system captures images using usb camera, compressed using DCT technique and send video via GPRS module to receiver centre. At receiver side using socket programming and MPEG streamer user can monitor videos. This System is supported by embedded Linux operating system.

With combination of ARM 9 and embedded Linux, this system provides low cost and low power consumption which can be used for security purpose at home, hospitals and malls etc.

Keywords: ARM9, USB Camera, GPRS, MJPEG streamer

1. INTRODUCTION

In this system , we have proposed mini2440 development board having S3c2440 microprocessor and embedded Linux operating sytem. S3C2440 is a RISC microprocessor based on ARM920T.The maximum frequency can reach 533MHz. Using USB camera, image is captured and compressed using application program using DCT technique. Using GPRS module and client socket programming images are transferred remotely to receiver side. At receiver, using server socket programming and MPEG streamer, user is able to watch videos as well as static images.

1.1 SYSTEM ARCHITECTURE

In this system, the usb camera will capture the image and send it to mini2440 ARM 9 board through USB device. Using application program image is compressed send to receiver by using GPRS module. At receiver side using internet and MJPEG streamer we can monitor video. The system's hardware architecture is as shown in Figure. Here we have proposed Logitech C170 USB Camera, SIM900A- RS232 GPRS Module.

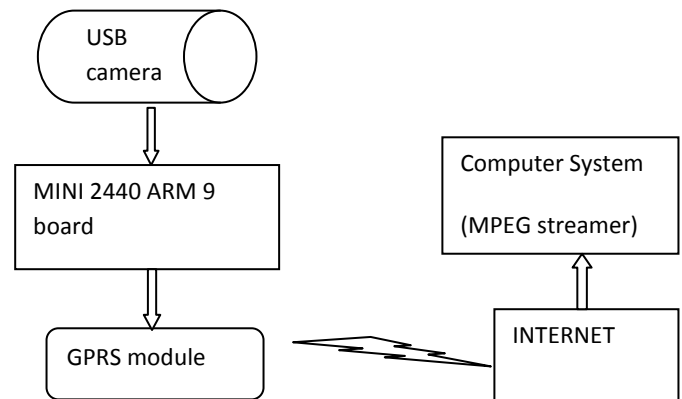

Fig-1 Hardware structure

2. MINI 2440 Development Board

The Mini 2440 Single Board Computer is a high-performance controller board. It is designed based on the S3C2440 microcontroller, 256MByte DDR SDRAM, 1GByte NAND Flash, RTC, Audio and net on board. It has integrated RS232, USB, Ethernet, Audio In/Out, Keyboard, LCD, CVBS, TV out, camera in, SD card and more other functions on board. So many hardware resources provided by the expansion board, it becomes a solid reference board for customer design.

The S3C2440X is a 16/32-bit RISC microprocessor, which is designed to provide a cost effective, low-power capabilities, high performance Application Processor solution for mobile phones and general applications. To provide optimized H/W performance for the 2.5G & 3G communication services, the S3C2440X adopts 64/32-bit internal bus architecture. It also includes many powerful hardware accelerators for tasks such as motion video processing, audio processing, 2D graphics, display manipulation and scaling. An integrated Multi Format Codec (MFC) supports encoding and decoding of MPEG4/H.263/H.264 and decoding of VC1. To reduce total system cost and enhance overall functionality, the S3C2440X includes many hardware peripherals such as a Camera Interface, TFT 24-bit true color LCD controller, System Manager (power management & etc.), 4-channel

UART, 32-channel DMA, 5-channel 32bit Timers with 2PWM output, General Purpose I/O Ports, I2S-Bus interface, I2C-BUS interface, USB Host, USB OTG Device operating at high speed (480Mbps), 3-channel SD/MMC Host Controller and PLLs for clock generation.



Fig2. MINI 2440 development board

The board supports Linux 2.6.32, Android2.1 and Windows CE 6.0 operating system and is provided with complete basic drivers which enable a quick channel to evaluate the Samsung S3C2440 processor and customize application software. It would be an ideal development platform for multimedia and communication applications.

In proposed system, Embedded Linux operating system is used.

2.1 Transplantation of Embedded Linux Operating System in mini2440:

To work with mini2440, we have to transplant required operating system in mini2440 development board. This board supports :Linux2.6.32.2 + Qtopia-2.2.0 + QtE-4.7.0 and WindowsCE.NET 6.0(R3) operating system. Here we have proposed Linux 2.6.32.2 operating system as it open source which provides many components for standard features, from hardware support to network protocols, going through multimedia, graphic, cryptographic libraries, etc.

The Linux operating system's transplant needs to complete three works: boot loader transplant, Linux kernel transplant and file system transplant.

We have different tools to perform transplantation like DNW and Minitool.

With DNW, we can transplant supervivi bootloader, Zimage of kernel and root_qtopia-64M.img or root_qtopia-128M.img for file system. With Minitool, we can transplant Superboot bootloader, zimage of kernel and root-qtopia-qt4.img for files system.

Here we have proposed supervivi bootloader .Hence we are using DNW tool which require USB driver to install.

Installation of USB Driver: DNW USB driver should install when board is connected to PC. When we Open DNW, "usb:ok" will indicated on DNW title bar if USB connection successfully.

Boot loader transplant: Boot loader is running before the operating system kernel, which will initialize hardware equipment(including I/O, the special function register), establish the memory space map and bring the environment of the system's hardware and software to an appropriate state.

Boot Mode: Boot mode can be selected by switch S2. System will boot from Nand Flash.

Switch S2 is set to Nor Flash to enter in BIOS main menu after power on:

Supervivi is a boot loader based on Samsung open source vivi. It can be used as a tool to download and burn OS image to the flash on board. It can also be used to for parameters configuration.

Linux kernel transplant: The Linux operating system's kernel provides good support to the ARM processor and manage most of components which connect to the periphery of the processor.

Click DNW USB Port->Transmit to select zimage_w35 kernel image file. This file is depends on LCD version.

File system transplant: Click DNW USB Port->Transmit to select rootfs_qtopia_qt4 yaffs file system image file to download.

Application program transplantation:

To perform different task like video capture, compression and sending packets through GPRS service, we require to load different executable files into Mini2440 board through host device i. e. PC. We can use linux operating system like Fedora 11 or Ubuntu 12.04 versions.

Initially it is necessary to install cross compiler on host system to make executables for ARM platform. We proposed arm linux gcc 4.4.3 compiler for compilation of application programs.

We can access terminal of MINI2440 using serial terminal programs like hyper terminal/Putty/Minicom. We can port executable in MINI2440 by different ways like serial terminal, Using a Pen drive or SD Card, Using File Transfer Protocol FTP method, Using NFS – Network File System service.

3. Program design of image acquisition[3]

Video For Linux Two is the second version of the Video For Linux API, a kernel interface for analog radio and video capture and output drivers. V4L2 drivers are implemented as kernel modules, loaded manually by the system administrator or automatically when a device is first opened. The driver modules plug into the "videodev" kernel module. Driver supports video capturing through /dev/video0. /dev/video captures images. To open and close V4L2 devices application program uses the open() and close() function, respectively. Devices are programmed using the ioctl() function.

a) Open the video equipment: The device name of USB camera in Linux is /dev/video0. The Linux kernel supports UVC (**USB video device class**) based cameras. UVC is a USB device class that describes devices capable of streaming video like webcams, digital camcorders, transponders, analog video converters, television tuners, and still-image cameras. Here we use Logitech web camera which is UVC based so that there is no requirement for drivers needed to capture images from the camera. We can connect Logitech C170 usb camera to mini2440.[3]

b) Read the video information: Reading video information is mainly to read the basic information and images property of equipment, which could be performed through the ioctlO function's control commands.

c) Video Capture:

We can Video through mmapO function.

The image data could be saved as a file after the image acquisition finished.

d) Close device:

The video equipment must be closed after Video Capture.

First the video data of collection is compressed into JPEG. Then the data is packaged into the data packet transmission to the video application server for processing.

3.1 Video Compression

The JPEG compression encoding scheme is used in the system based on the DCT (Discrete Cosine Transform) sequence. The JPEG encoding under Linux can use the library Libjpeg, that is used under linux standard library, and its function is the picture in accordance with a certain percentage of compressed into JPEG format pictures or JPEG format to decompress. Many software operating on JPEG are based on this library. Mini2440 supports jpeglib 62 library version. In application program we can include jpeglib library file for DCT compression. In host device i.e. PC we can compile application program for image capture and image compression using ARM cross compiler.

4. Program design for networking:

GPRS communication module [2]

General Packet Radio Services (GPRS) is a packet oriented mobile data service on 2G and 3G cellular communication system's global system for mobile communication (GSM). GSM is the most widely used mobile technology using a simple Subscriber Identity Module (SIM) it has taken the world of mobile communication to new heights. Even with the introduction of new technologies like CDMA, GSM has stood its strength due to its efficiency and simplicity.

A GSM modem is a wireless modem that works with a GSM wireless network. Computers use AT commands to control modems. Both dial-up modems and GSM modems support a common set of standard AT commands. So we can use a GSM modem just like a dial-up modem. A wireless modem sends and receives data through radio waves.

System programming is divided into client and server programming. The client program collect data and send using GPRS service and server program receive the data. For this purpose, the socket programming is used.

The socket is the interface of the same host between the application layer and transport layer. TCP or UDP may be used to provide concurrent services for more than one application process while communicating between application layer and

transport layer. In order to distinguish between different application processes and connections, many computer operating systems provide for the application by TCP / IP protocol. The interact is called the socket. Its main parameters are three: the destination IP address, transport layer protocol and port number.

We can stream video on MJPG-streamer, a command line application. It copied JPG-frame from a single input plug-in to multiple output plugins. It can be used to stream JPEG files over an IP-based network from the webcam to a viewer like Firefox, Cambozola, Videolanclient or even to a Windows Mobile device running the TCPMP-Player.

5. CONCLUSIONS

Proposed system gives solution for wireless video streaming used for security purpose at home, hospitals and mall etc. We can minimize cost and power consumption by introducing embedded system.

REFERENCES:

- [1] Lihui Zhao, Chunbao Huo, Hongzhe Yang China "The Design of Remote Video Monitoring System Based on S3C2416 and GPRS" International Conference on System Science and Engineering June 30-July 2, 2012, IEEE
- [2] Ayesha M. Anwar Khan, Prof. Chanchal V. Dahat "Remote Video surveillance System Based on S3C2440 and GPRS" IJAR in Computer Science and Management Studies, Volume 2, Issue 6, June 2014 ISSN: 2321-7782 (Online)
- [3] G.Mounisha, J.Vamsikrishna, D.Prashant "Network Video Capture and Motion Detection Based On Embedded Linux with GSM Service" International Journal Of Engineering And Computer Science ISSN:2319-7242 Volume 3 Issue 11 November, 2014 Page No. 9133-9135
- [4] www.FriendlyARM.net
- [5] s3c2440 manual