

# Comparative Performance of MIMO Channel Estimation Techniques

Paresh Naik<sup>1</sup>, Nisha S L<sup>2</sup>

<sup>1</sup> P.G. student, Digital Communication Engineering, M S Ramaiah Institute of Technology, Karnataka, India

<sup>2</sup> Assistant Professor, M S Ramaiah Institute of Technology, Bangalore, Karnataka, India

\*\*\*

**Abstract** - With the increase in wireless technological development, there is a need for innovative designed to integrate features such as high data rates, high quality of service and multimedia in the existing communication framework. In wireless systems, radio signals are corrupted due to fading, interference and noise. In order to handle the effects of fading and interference, modern systems employ various techniques including multi-antenna transceivers. Initially, multi-antenna systems were proposed only for point-to-point communication. MIMO system contain multiple input multiple output from  $m$  transmitters and  $n$  receivers. Using Multiple Input Multiple Output (MIMO) systems we can reduce the effect of fading and noise in the channel. Multiple signals are transmitted from different antennas at the transmitter using the same frequency and separated in space. Received signal in MIMO system is usually distorted by multipath fading. In order to recover the transmitted signal correctly, channel effect must be estimated and repaired at receiver. Various channel estimation techniques are employed in order to judge the physical effects of the medium present. Hence MIMO systems utilizes space multiplex by using array of antenna's for enhancing the efficiency at particular utilized bandwidth. MIMO use multiple inputs multiple outputs from single channel. These systems defined by spectral diversity and spatial multiplexing. The aim of this paper is to design and implement of channel estimation method and modulation technique for MIMO system. In this project channel estimation techniques such as Zero forcing, Minimum Mean Square Error (MMSE) and Space Time Block Codes (Alamouti code) for MIMO system are implemented in Matlab using modulation techniques like BPSK and QPSK. These techniques are compared effectively to estimate the channel in MIMO Systems. Space Time Block Codes gives better performance in terms of bit error rate and signal to noise ratio.

**Key Words:** Multiple Input Multiple Output (MIMO), Binary Phase Shift Keying (BPSK), Quadrature Phase Shift Keying (BPSK), Zero Forcing (ZF), Minimum Mean Square Error

## 1. Introduction

MIMO technology is being used and proposed in the near future for many modern wireless systems in many different scenarios to combat against fading and to improve performance. Basically, these techniques transmit

different data streams on different transmit antennas simultaneously. By designing an appropriate processing architecture to handle these parallel streams of data, the data rate and/or the Signal-to-Noise Ratio (SNR) performance can be increased. The MSE of the LS MIMO channel estimator algorithm is derived as a closed-form function of the Doppler frequency shift, forgetting factor, channel dimensions and the length of the training sequences [1]. The performance of MIMO channel is increase by using different channel estimation such as Zero forcing (ZF), Minimum mean square error (MMSE) and Maximal ratio combining (MRC) techniques [2]. The space time code used is Alamouti's ST Block Code which gives very good performance and is quite simple to implement. So that the MIMO system is best suitable for the WMAN technology [5]. The parameter mean square error (MSE) and symbol error rate (SER) comparisons between LS and MMSE estimator. The performance of the MMSE estimator is better than the LS estimator MIMO-OFDM fulfills the high data rate requirement through spatial multiplexing gain and improved link reliability due to antenna diversity gain.

In wireless communication the signal get corrupted due to fading in the signal, which is occurs due to noise. During the transmission of signal noise is added, so we may not get original signal back at the receiver. To minimize these error channel estimation algorithm are used at the receiver. In MIMO system channel estimation is needed. The different channel estimation algorithm used are Zero forcing, MMSE, Alamouti code.

## 2. Channel Estimation

Channel estimation is an important technique especially in mobile wireless network systems where the wireless channel changes over time, usually caused by transmitter and/or receiver being in motion at vehicular speed. Mobile wireless communication is adversely affected by the multipath interference resulting from reflections from surroundings, such as hills, buildings and other obstacles. In order to provide reliability and high data rates at the receiver, the system needs an accurate estimate of the time-varying channel. The different channel estimation techniques used in this paper are discussed below. The block diagram of channel estimation as shown in fig-1 .

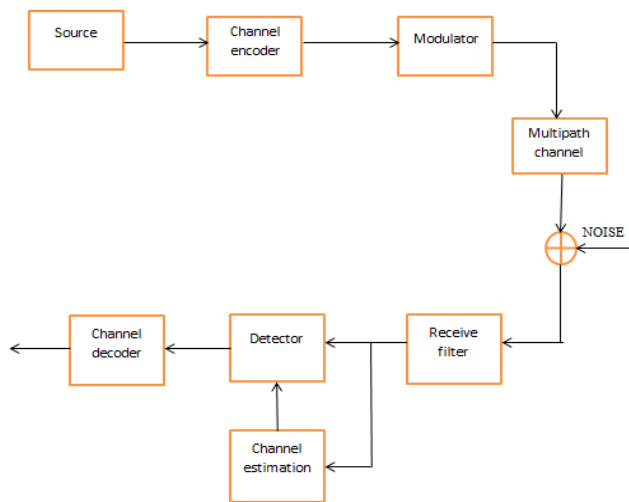

Fig-1: Block diagram of channel estimation

### 2.1 2x2 MIMO systems

In any communication system noise get added in the channel with the signal transmitted. The digital signal transmitted over a faded multi-path channel 'h'. The noise get added which is modeled as additive white Gaussian noise 'n'. The demodulation problem is to detect the transmitted bits 'x' from the received signal 'y'. The received signal also has channel coefficients multiplied. The detector needs these channel estimates for that specific channel and channel estimation device.

The received signal y is given as

$$y = hx + \eta \quad (1)$$

The training sequence is transmitted so that the channel coefficients are calculated. First the transmitter is made active and the training sequence is sent. The tx2 is made inactive i.e. nothing is sent from tx2. The h11 and h12 channel coefficients are obtained. Then the tx1 is made inactive and tr2 is sent through tx2. The data obtained at the receivers rx1 and rx2 are shown by the equations 2 and 3

$$y_1 = h_{1,1}x_1 + h_{1,2}x_2 \quad (2)$$

$$y_2 = h_{2,1}x_1 + h_{2,2}x_2 \quad (3)$$

This project aims at simulation of a simple and most efficient channel estimation method and a good modulation technique for increasing the channel capacity, bandwidth, increasing bit rates and eliminates inter symbol interference. There are well-known training based channel estimation methods are; Zero forcing, Minimum Mean Square Estimation (MMSE), Alamouti code. The main aim is to reduce the computational complexity of channel estimation using different algorithm and implementing 2x2 MIMO system using BPSK and QPSK modulation technique. Fig-2 shows the block diagram of the project.

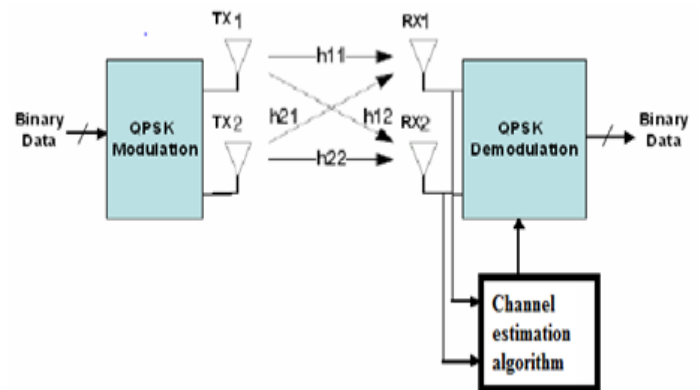

Fig-2: Block diagram of project

### 2.2 Zero forcing

The ZF-equalizer is designed using the peak-distortion criterion. Ideally eliminates all ISI. The names zero forcing corresponds to bringing down to inter-symbol interference to zero in a noise free case. This will be useful when ISI is significant compared to noise. Zero-forcing equalizers ignore the additive noise and may significantly amplify noise for channels with spectral nulls. The channel is flat fading; it means that the multipath channel has only one tap. The channel experience by each transmit antenna is independent from the channel experienced by other transmit antennas. For the  $i^{th}$  transmit antenna to  $j^{th}$  receive antenna, each transmitted symbol gets multiplied by a randomly varying complex number  $h_{j,i}$ . As the channel under consideration is a Rayleigh channel, the real and imaginary parts of  $h_{j,i}$  are Gaussian distributed having mean zero and variance 0.5. The channel experienced between each transmit to the receive antenna is independent and randomly varying in time. On the receive antenna, the noise  $\eta$  has the Gaussian probability density function with

$$p(\eta) = \frac{1}{\sqrt{2\pi\sigma^2}} e^{-\frac{(\eta-\mu)^2}{2\sigma^2}} \quad (4)$$

The received signal is given by

$$\begin{bmatrix} y_1 \\ y_2 \end{bmatrix} = \begin{bmatrix} h_{1,1} & h_{1,2} \\ h_{2,1} & h_{2,2} \end{bmatrix} \begin{bmatrix} x_1 \\ x_2 \end{bmatrix} + \begin{bmatrix} \eta_1 \\ \eta_2 \end{bmatrix} \quad (5)$$

- Initialize the SNR value, both high and low SNR value is been considered in the project.
- Initially the filter coefficients are generated, using these coefficients hermitian matrix H is computed

and the equalizer coefficient  $W$  using the equation

$$W = (H^H H)^{-1} H^H \tag{6}$$

where  $H$  represents the hermitian matrix and  $I$  represents the identity matrix.

- In Zero forcing algorithm the noise term is consider as zero. Real and imaginary values of  $W$  are multiplied by the output of the channel. And the estimate of input signal is done
- .Our design criterion is to minimize the error between the estimated signal and the input signal. After computing the estimated value, find the BER using estimated value and input signal. Finally plot the simulation result using the BER and SNR value.

### 2.3 Minimum Mean Square Error (MMSE)

In statistics and signal processing, a minimum mean square error (MMSE) estimator is an estimation method which minimizes the mean square error (MSE) of the fitted values of a dependent variable, which is a common measure of estimator quality.

- Initialize the SNR value, both high and low SNR value is been considered in the project.
- The received signal is given by

$$\begin{bmatrix} y_1 \\ y_2 \end{bmatrix} = \begin{bmatrix} h_{1,1} & h_{1,2} \\ h_{2,1} & h_{2,2} \end{bmatrix} \begin{bmatrix} x_1 \\ x_2 \end{bmatrix} + \begin{bmatrix} \eta_1 \\ \eta_2 \end{bmatrix} \tag{7}$$

- Initially the filter coefficients are generated, using these coefficients hermitian matrix  $H$  is computed and the equalizer coefficient  $W$  using the equation

$$W = [H^H H + N_0 I]^{-1} H^H \tag{8}$$

where  $H$  represents the hermitian matrix,  $N_0$  is the noise in the signal and  $I$  represent the identity matrix.

The difference between Zero forcing and MMSE channel estimation is in MMSE estimation we are considering the noise. Real and imaginary values of  $W$  are multiplied by the output of the channel. And the estimate of input signal is done .Our design criterion is to minimize the error between the estimated signal and the input signal. After computing the estimated value, find the BER using estimated value and input signal. Finally plot the simulation result using the BER and SNR value.

### 2.4 Alamouti code

Space-time block coding (STBC) has been demonstrated to be a powerful diversity technique to combat channel fading in wireless communication. In particular, the Alamouti code offers very simple encoding/decoding and is particularly suitable for future wireless systems Space-time block coding is a technique used in wireless communications to transmit multiple copies of a data stream across a number of antennas and to exploit the various received versions of the data to

improve the reliability of data-transfer. The fact that the transmitted signal must traverse a potentially difficult environment with scattering, reflection, refraction and so on and may then be further corrupted by thermal noise in the receiver means that some of the received copies of the data will be better than others. This redundancy results in a higher chance of being able to use one or more of the received copies to correctly decode the received signal. In fact, space-time coding combines all the copies of the received signal in an optimal way to extract as much information from each of them as possible.

- The very first step is to initialize the parameter such as SNR, number of transmitter and receiver and number of sample.
- The received signal at time slot 1 and time slot 2

$$\begin{bmatrix} y_1^1 \\ y_2^1 \\ y_1^{2*} \\ y_2^{2*} \end{bmatrix} = \begin{bmatrix} h_{11} & h_{22} \\ h_{21} & h_{22} \\ h_{12}^* & -h_{11}^* \\ h_{22}^* & -h_{21}^* \end{bmatrix} \begin{bmatrix} x_1 \\ x_2 \end{bmatrix} + \begin{bmatrix} \eta_1^1 \\ \eta_2^1 \\ \eta_1^{2*} \\ \eta_2^{2*} \end{bmatrix} \tag{9}$$

- The add the AWGN signal with the modulated data and find the channel coefficient and hermitian matrix.

$$H = \begin{bmatrix} h_{11} & h_{22} \\ h_{21} & h_{22} \\ h_{12}^* & -h_{11}^* \\ h_{22}^* & -h_{21}^* \end{bmatrix} \tag{10}$$

- Next is to compute the estimated value from the from the estimated equation and calculate the BER in the system.

$$\begin{bmatrix} x_1 e \\ x_2 e \end{bmatrix} = (H^H H)^{-1} H^H \begin{bmatrix} y_1^1 \\ y_2^1 \\ y_1^{2*} \\ y_2^{2*} \end{bmatrix} \tag{11}$$

### 3. Results

Communication system Toolbox provides algorithms and tools for the simulation of communication system. These capabilities are provided as MATLAB® functions, MATLAB system objects. The Zero forcing(ZF), Minimum mean square error(MMSE) and alamouti code are coded and simulated in MATLAB .The results are tabulated and the bit error rates (BER) using two different modulation schemes BPSK and QPSK . The performance of wireless communication system is defined in terms of the bit-error-rate (BER) and symbol-error-rate (SER) which is rely on

the signal to noise ratio (SNR). The BER is a key feature for all digital communication system that gives a foundation for the amount of information transferred from the transmitter to receiver and the design of the system is depending on type of channel and type of modulation.

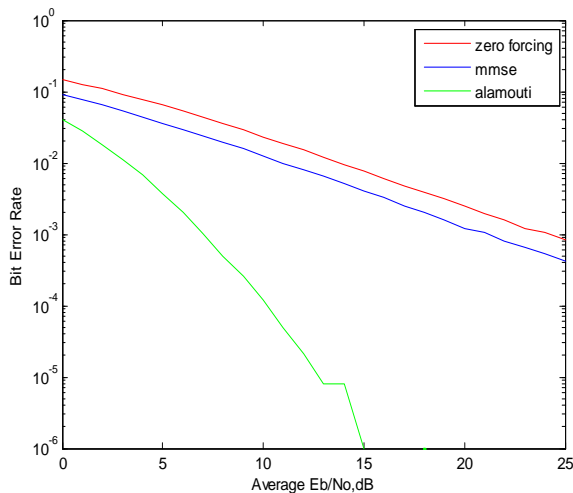

**Fig-3:** BER for BPSK modulation with 2Tx, 2Rx MIMO Zero forcing, MMSE, Alamouti STBC (Rayleigh channel)

Fig 3 and Fig 4 shows the BER performance of different channel estimation techniques with BPSK modulation for low and high SNR respectively. It is observe from the result that the Alamouti STBC code gives better performance as compared to Zero forcing, MMSE. It is clear that with increase in the signal to noise ratio from 0 to 25, the BER decreases from 0.1446 to 0 for Zero forcing, 0.0926 to 0 for MMSE and 0.0412 to 0 for Alamouti code with using BPSK modulation technique and fro SNR ranging from 0 to 100 BER decrease from 0.1462 to 0 for Zero forcing, 0.0923 to 0 for MMSE and 0.0401 to 0 for Alamouti code using BPSK modulation.

In alamouti technique, transmit multiple copies of a data stream across a number of antennas and to exploit the various received versions of the data to improve the reliability of data-transfer. The fact that the transmitted signal must traverse a potentially difficult environment with scattering, reflection, refraction and so on and may then be further corrupted by thermal noise in the receiver means that some of the received copies of the data will be better than others. This redundancy results in a higher chance of being able to use one or more of the received copies to correctly decode the received signal. The MMSE equalizer results in around 3dB of improvement when compared to zero forcing equalizer. Fig 4 it is observed that at high SNR, MMSE estimator and ZF estimator performance is almost equal.

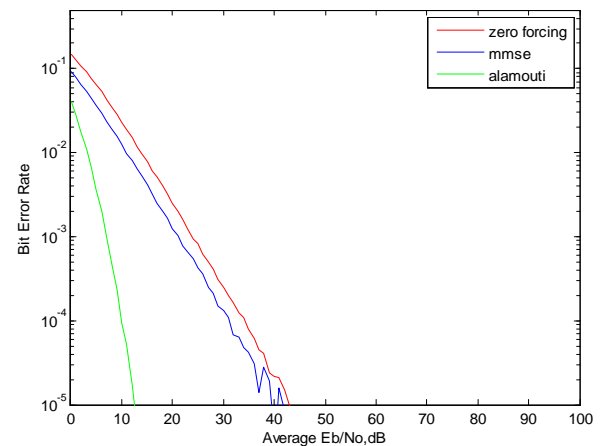

**Fig-4 :** BER for BPSK modulation with 2Tx, 2Rx MIMO Zero forcing, MMSE, Alamouti STBC (Rayleigh channel) for high SNR

Fig 5 and Fig 6 shows the BER performance of different channel estimation techniques with QPSK modulation for low and high SNR respectively. It is observe from the result that the Alamouti STBC code gives better performance as compared to Zero forcing, MMSE. It is clear that with increase in the signal to noise ratio from 0 to 25, the BER increases from 0.4997 to 0.5009 for Zero forcing, 0.4996 to 0.5003 for MMSE and 0.4994 to 0.5004 for Alamouti code with using QPSK modulation technique and for SNR ranging from 0 to 100 BER increases from 0.4995 to 0.5004 for Zero forcing, 0.4993 to 0.5004 for MMSE and 0.4996 to 0.5003 for Alamouti code using QPSK modulation.

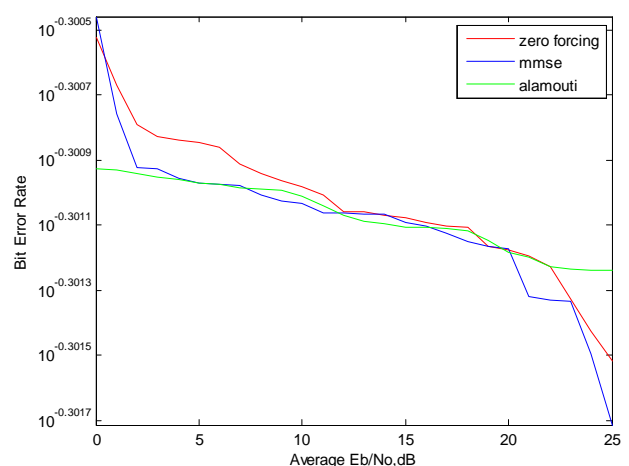

**Fig-5:** BER for QPSK modulation with 2Tx, 2Rx MIMO Zero forcing, MMSE, Alamouti STBC (Rayleigh channel)



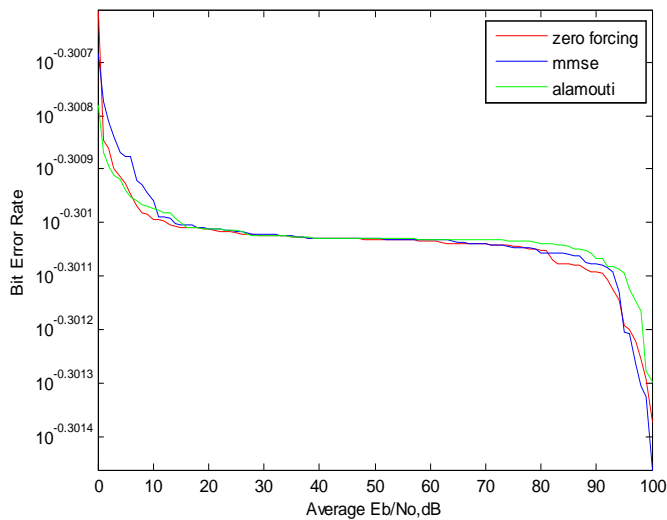

**Fig 7.10** BER for QPSK modulation with 2Tx, 2Rx MIMO Zero forcing, MMSE, Alamouti STBC (Rayleigh channel) for high SNR

Comparing Zero forcing, MMSE and Alamouti code channel estimation algorithms for BPSK and QPSK modulation techniques Bit error rate is less for BPSK when compared to QPSK as shown in the tables 1 .Bit error rate for low and high SNR are tabulated for the three algorithms. For BPSK Alamouti shows better performance whereas for QPSK all three algorithms shows increased BER.

**Table-1:** BER Comparison of ZF, MMSE and Alamouti channel estimation algorithms

Channel estimation Algorithms	Modulation techniques			
	BPSK		QPSK	
	Low SNR	High SNR	Low SNR	High SNR
Zero forcing	0.1446	0.1462	0.5006	0.4997
MMSE	0.0926	0.0923	0.499	0.4996
Alamouti	0.0412	0.0401	0.5023	0.4994

#### 4. CONCLUSIONS

A 2x2 MIMO system has been implemented using modulation techniques like Binary phase shift keying (BPSK) and Quadrature phase shift keying (QPSK). The results are compared with each other based on BER and SNR. The simulation study on the performance analysis of MIMO 2x2 based on channel estimation algorithms like Zero forcing, MMSE and Alamouti code for MIMO wireless channel is compared. From the simulation it can be concluded that the Alamouti (STBC) code channel estimation algorithm gives better performance than the Zero forcing and MMSE channel estimation algorithms.

#### REFERENCES

- [1] Karami, Ebrahim. "Tracking performance of least squares MIMO channel estimation algorithm." *Communications,IEEE Transactions on* 55.11 (2007): 2201-2209.
- [2] Malik, Dhruv, and Deepak Batra. "Comparison of various detection algorithms in a MIMO wireless communication receiver." *International Journal of Electronics and Computer Science Engineering,(ISSN: 2277-1956)* 1.3 (2012).
- [3] Basnayaka, Dushyantha A., Peter J. Smith, and Philippa A. Martin. "Performance analysis of dual-user macrodiversity MIMO systems with linear receivers in flat Rayleigh fading." *Wireless Communications, IEEE Transactions on* 11.12 (2012): 4394-4404.
- [4] Gesbert, David, et al. "From theory to practice: an overview of MIMO space-time coded wireless systems." *Selected Areas in Communications, IEEE Journal on* 21.3 (2003): 281-302.
- [5] Drieberg, Micheal, Yew Kuan Min, and Varun Jeoti. "A simple channel estimation method for mimo-ofdm in ieee 802.16 a." *TENCON 2004. 2004 IEEE Region 10 Conference. IEEE, 2004.*
- [6] Aryal, S. R., and H. Dhungana. "Channel Estimation in MIMO-OFDM System." *Nepal Journal of Science and Technology* 14.2 (2014): 97-102.
- [7] Chen, Enqing, Xiaoqiang Xiang, and Xiaomin Mu. "Channel estimation for MIMO-OFDM systems based on subspace Pursuit algorithm." *Circuits and Systems (ISCAS), 2013 IEEE International Symposium on. IEEE, 2013.*
- [8] Cicerone, Marcello, Osvaldo Simeone, and Umberto Spagnolini. "Channel estimation for MIMO-OFDM systems by modal analysis/filtering." *Communications, IEEE Transactions on* 54.11 (2006): 2062-2074.
- [9] Li, Ye. "Simplified channel estimation for OFDM systems with multiple transmit antennas." *Wireless Communications, IEEE Transactions on* 1.1 (2002): 67-75.
- [10] Coleri, Sinem, et al. "Channel estimation techniques based on pilot arrangement in OFDM systems." *Broadcasting, IEEE Transactions on* 48.3 (2002): 223-229.

- [11] Li, Wenyu, and Norman C. Beaulieu. "Effects of channel-estimation errors on receiver selection-combining schemes for Alamouti MIMO systems with BPSK." *Communications, IEEE Transactions on* 54.1 (2006): 169-178.
- [12] Alamouti, Siavash. "A simple transmit diversity technique for wireless communications." *Selected Areas in Communications, IEEE Journal on* 16.8 (1998): 1451-1458.
- [13] Tan, Chee Wei, and A. Robert Calderbank. "Multiuser detection of Alamouti signals." *Communications, IEEE Transactions on* 57.7 (2009): 2080-2089.
- [14] Caplan, Scott, Dmitri Williams, and Nick Yee. "CHANNEL ESTIMATION IN MIMO-OFDM SYSTEMS BASED ON COMPARATIVE METHODS BY LMS ALGORITHM."
- [15] Chaudhary, Shubhangi R., and A. J. Patil. "PERFORMANCE OF SPATIAL MULTIPLEXING, DIVERSITY AND COMBINED TECHNIQUE FOR MIMO-OFDM SYSTEM."
- [16] Parveen, Nazia, and D. S. Venkateswarlu. "Implementation of Space-Time Block Coding (STBC) Using 2 Transmit and 2 Receive Antennas." *International Journal of Emerging Technology and Advanced Engineering* 2.10 (2012): 175-178.

## BIOGRAPHIES



Paresh Naik, Completed B.E. in Telecommunication Engg from VTU, Belgaum-2013 and Currently pursuing M.Tech final sem in Digital Communication Engg



Nisha S L, Completed M.Tech in Digital communication Engg from BMSCE, Bangalore-2010 Currently working as an Assistant Professor in MSRIT, Bangalore with a teaching experience of 12 years and presented 7 technical papers in which 1 international and 6 national level conferences.