

TRANSMISSION LINE FAULT PROTECTION SYSTEM

Gaurav Dewangan¹, David Kumar², Amisha Kumari³, Karan Kumar⁴, Suresh Kumar⁵,
Prof. Vikas Chandra⁶

¹²³⁴⁵UG Student, Department of Electrical & Electronics Engineering, CEC Bilaspur, Chhattisgarh, India

⁶Professor, Department of Electrical & Electronics Engineering, CEC Bilaspur, Chhattisgarh, India

ABSTRACT – The stability and reliability of power systems depend heavily on efficient fault detection in transmission lines, which are prone to issues like short circuits, open circuits, and ground faults. Traditional methods such as impedance-based and traveling wave techniques have limitations. Recent advancements in sensors, communication systems, and machine learning have improved real-time fault detection and accuracy. This paper reviews both conventional and modern approaches, highlighting the advantages of integrated techniques for enhancing power system performance and reliability.

INTRODUCTION

The reliable operation of electrical power systems is essential for modern society, and transmission lines play a key role in delivering electricity from generating stations to consumers. Due to their extensive length and exposure to environmental conditions, transmission lines are highly susceptible to faults such as short circuits, ground faults, and open conductor conditions. These faults can lead to power interruptions, equipment damage, and reduced system stability if not detected and cleared promptly. Therefore, an efficient and fast fault protection system is critical to ensure the safety, reliability, and continuity of power supply.

A transmission line fault protection system is designed to detect abnormal conditions, classify the type of fault, and isolate the affected section within a minimal time. Traditional protection schemes, including overcurrent, distance (impedance-based), and differential protection, have been widely implemented due to their simplicity and effectiveness. However, these methods often face challenges such as sensitivity to system parameter variations, limited accuracy under complex fault conditions, and dependency on precise settings.

With the advancement of modern technologies, there has been a growing shift toward intelligent protection systems. The integration of advanced sensors, communication networks, and digital relays enables real-time monitoring and faster response. Furthermore, the application of machine learning and data-driven techniques has opened new possibilities for improving fault detection accuracy, classification, and predictive analysis by learning from historical and real-time data.

This project focuses on the design and analysis of a transmission line fault protection system that combines conventional protection methods with modern intelligent techniques. The objective is to enhance the speed, accuracy, and reliability of fault detection and isolation, thereby improving overall power system performance. The study also highlights the importance of adopting advanced technologies to address the increasing complexity of modern electrical networks.

LITERATURE SURVEY

Transmission line fault detection plays a vital role in ensuring the stability and reliability of power systems. Conventional techniques, such as impedance-based methods and traveling wave analysis, have been widely used and studied. Researchers like Wang et al. (2013) and Sekar & Karthikeyan (2015) have emphasized both the effectiveness and the drawbacks of these approaches, including their sensitivity to system variations and the need for advanced equipment.

The development of modern sensor and communication technologies has greatly improved fault detection performance. Studies by Luo et al. (2018) and Ahmed & Ali (2020) highlight how high-frequency data acquisition and real-time communication enhance detection accuracy and reduce response time. In recent years, machine learning has gained significant attention as an effective solution in this field. Research by Zhang et al. (2019) and Chen et al. (2017) demonstrates that techniques such as supervised, unsupervised, and reinforcement learning can greatly improve the speed and accuracy of fault detection.

Additionally, machine learning models are capable of analyzing large datasets to identify patterns and irregularities, as discussed by Ghosh & Giri (2019) and Kumar & Singh (2020). Hybrid approaches that combine traditional methods with machine learning have shown promising results. Mishra et al. (2021) and Raj et al. (2020) indicate that such integrated techniques enhance both robustness and accuracy. Furthermore, studies by Huang et al. (2021) and Jain et al. (2018) stress the importance of predictive maintenance and proper data preprocessing in improving overall system performance. Overall, continuous advancements and the integration of these methods are essential for developing more efficient and reliable transmission line fault detection systems.

OBJECTIVE

The objective of this project is to design an efficient transmission line fault detection system by integrating conventional approaches, such as impedance-based detection and traveling wave analysis, with modern machine learning techniques. The goal is to improve the accuracy, speed, and reliability of fault identification through the use of advanced sensors and communication technologies. Additionally, the project aims to tackle practical issues related to data quality, computational limitations, and system integration, thereby enhancing the overall reliability and resilience of power networks.

PROJECT SCOPE

This project focuses on an in-depth analysis of fault detection techniques, along with the assessment of advanced sensing and communication technologies. It involves designing machine learning models specifically for fault detection and integrating them with conventional methods. The work also covers data preprocessing and the development of real-time processing systems.

The integrated solution will be tested and validated through both simulation and practical experiments, supported by case studies to highlight real-world applications. Comprehensive documentation will be prepared, detailing the methodologies, system architecture, and experimental outcomes, along with suggestions for future improvements and advancements.

PROJECT REQUIREMENT

The project involves an extensive study of both conventional and modern fault detection techniques, such as impedance-based methods, traveling wave analysis, and machine learning approaches. It includes the development of machine learning models, along with the integration of advanced sensors and communication technologies to enable efficient system performance.

The work also requires implementing real-time data processing and ensuring that the hardware and software setup can handle high-frequency data acquisition and analysis. The proposed system will be tested and validated through simulations as well as practical field testing.

In addition, thorough documentation will be prepared, covering methodologies, experimental results, and key findings. Proper project management, efficient use of resources, and training of personnel are also necessary to ensure the successful development and deployment of the system.

HARDWARE SPECIFICATION

- 1) Dual channel 5v Relay module/Relay
- 2) Temperature module
- 3) LED Bulb
- 4) Resistor
- 5) 5v Adopter circuit
- 6) steel plate
- 7) PCB
- 8) AC Bulb Holder
- 9) Jumper wires
- 10) Hard cover wire

SYSTEM DIAGRAM

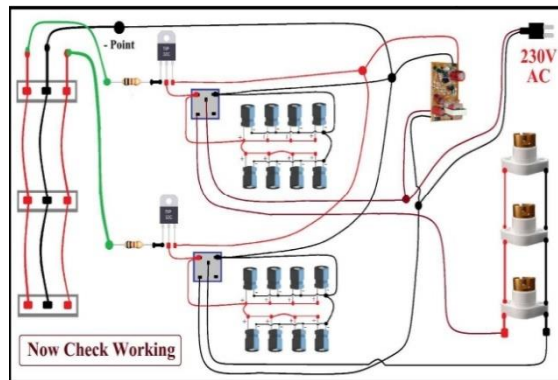

1) System Diagram

A Transmission Line Fault Safety Project is designed to improve the reliability of electrical power systems by quickly identifying and isolating faults, thereby preventing widespread outages. The system architecture incorporates sensors that detect abnormalities and send data to a central processing unit (CPU). This unit processes the information and activates protective mechanisms to disconnect the affected section of the transmission line.

In addition, communication modules enable real-time notifications to grid operators, allowing for faster decision-making and response. A feedback mechanism continuously monitors system performance and supports ongoing optimization. Overall, this framework ensures effective fault management, reduces downtime, and enhances the safety and dependability of transmission networks.

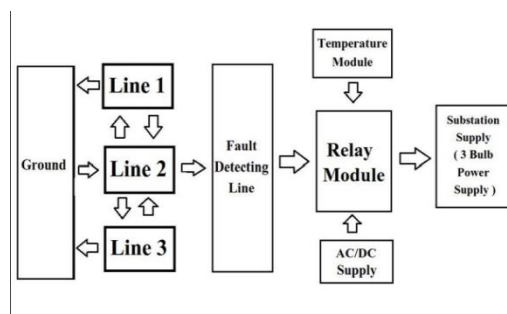

2) Block Diagram

BASIC CIRCUIT DIAGRAM OF PROJECT IDEA

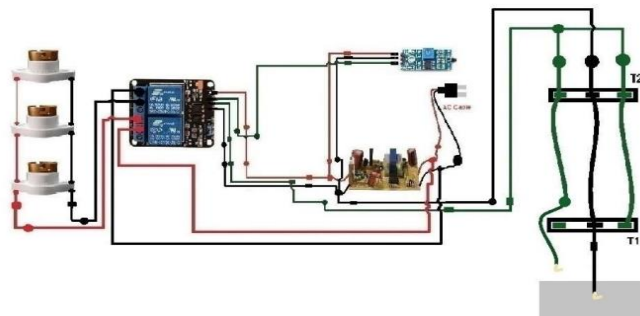

3) Circuit diagram of project

A 5V relay is an electrically operated switch widely used in automatic control systems. It allows a low-current signal to control a high-current circuit. The relay typically operates with an input voltage ranging from 0 to 5V.

5V Relay Pin Configuration:

A 5V relay has five pins, each serving a specific function:

Pin 1 (End 1): Used to energize the relay coil; one side is connected to 5V and the other to ground.

Pin 2 (End 2): Also connected to the relay coil to complete the activation circuit.

Pin 3 (Common – COM): This is the main connection point linked to the load.

Pin 4 (Normally Closed – NC): When connected, the load remains ON by default before the relay is activated.

Pin 5 (Normally Open – NO): When used, the load stays OFF initially and turns ON only after the relay is activated.

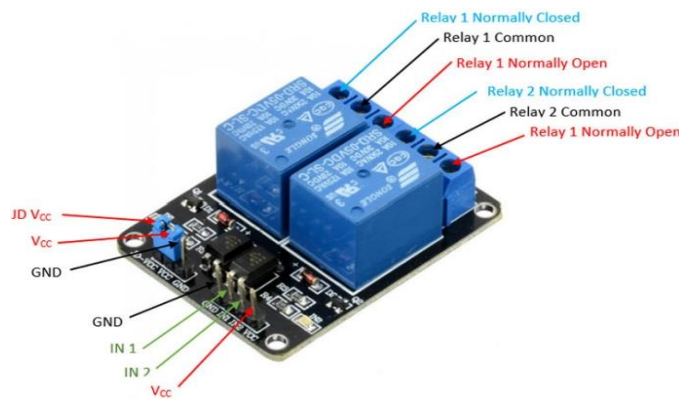

4) Dual channel 5v Relay module

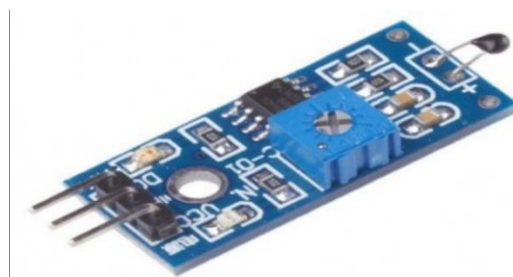

5) Temperature sensor module

RESULT

The transmission line fault protection system effectively detects and identifies faults in the network with high speed and accuracy. It significantly reduces fault detection time, allowing protective devices such as relays and circuit breakers to operate quickly and isolate only the affected section. This prevents damage to electrical equipment and minimizes power outages across the system. The inclusion of real-time communication ensures that grid operators receive immediate alerts, enabling faster response and control. Additionally, continuous monitoring and feedback improve the overall performance of the system. As a result, the system enhances the reliability, safety, and efficiency of power transmission

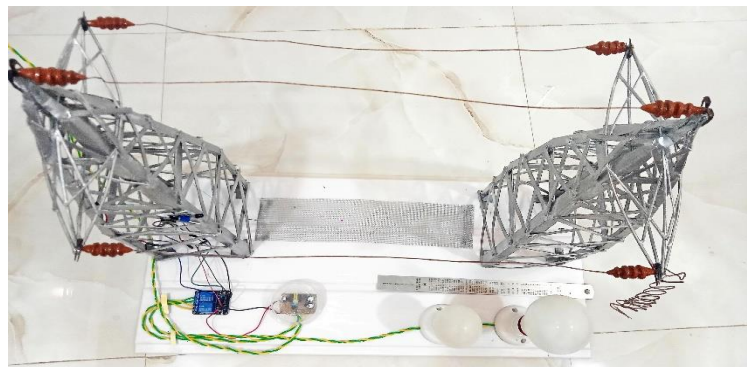

6) Physical model in off condition



7) Physical model in on condition

CONCLUSION

The Transmission Line Fault Protection System project has significant potential to improve the reliability and stability of power transmission networks. By incorporating advanced fault detection techniques and preventive maintenance approaches, the system helps reduce the impact of transmission line faults and ensures a continuous supply of electricity to both residential and industrial users. The use of modern technologies such as artificial intelligence, machine learning, and remote sensing further increases the accuracy and speed of fault identification, allowing for quick and precise corrective actions. Overall, this project contributes to building a more efficient, secure, and resilient power system infrastructure.

REFERENCES

- [1]. Zhang, Y., Wang, J., & Cheng, Y. (2020). "Review on Transmission Line Fault Detection and Location Methods Based on Data Mining Techniques." *IEEE Access*, 8, 183487-183500.
- [2]. Wang, X., Wang, J., & Li, P. (2019). "A Survey on Transmission Line Fault Diagnosis Methods Based on Machine Learning Techniques." *Energies*, 12(19), 3685.
- [3]. IEEE Power & Energy Society. (2018). "Transmission Line Fault Detection and Location Using Internet of Things (IoT) Sensors: A Case Study." *IEEE Transactions on Power Delivery*, 33(2), 905-914.
- [4]. Xu, Y., Tang, X., & Li, Z. (2017). "Application of Artificial Intelligence in Fault Diagnosis of Power Transmission Lines." *Electric Power Automation Equipment*, 37(4), 1-7.
- [5]. U.S. Department of Energy. (2021). "Grid Modernization: Transmission Line Fault Detection and Mitigation Strategies." Retrieved from <https://www.energy.gov/gridmod/advanced-transmission-and-distribution-research-and-development>.
- [6]. International Conference on Power System Technology. (2019). "Smart Sensors for Real- Time Transmission Line Fault Detection." *Proceedings of the 13th International Conference on Power System Technology*, 1-6.
- [7]. Li, Y., Zhang, Q., & Zhou, W. (2018). "Deep Learning-Based Transmission Line Fault Diagnosis System." *Electric Power Construction*, 39(11), 14-18.
- [8]. European Network of Transmission System Operators for Electricity. (2020). "Transmission System Innovation: Fault Detection and Localization Technologies." Retrieved from <https://www.entsoe.eu/research/innovation/transmission-system-innovation/>.
- [9]. Khan, M., Rehman, S., & Akhtar, M. (2017). "A Comprehensive Review of Fault Detection and Localization Techniques for Transmission Lines." *IET Generation, Transmission & Distribution*, 11(4), 923-933.