

# POWER SPHERE: SOLAR BASED WIRELESS EV CHARGING STATION USING RFID

Hirodkar Atharva Ravindra<sup>1</sup>, Dhum Riya Ramdas<sup>2</sup>, Pawar Sahil Prashant<sup>3</sup>, Lokhande Ishwari Sandip<sup>4</sup>, J.K.Dhavan<sup>5</sup>

<sup>1,2,3,4</sup> Student, MET's Institute of Technology – Polytechnic, Adgaon, Nashik, Maharashtra, India.

\*\*\*

**ABSTRACT** - In recent years, the rapid growth of electric vehicles (EVs) has increased the demand for efficient, safe, and convenient charging systems. Conventional wired charging methods involve physical connectors, which may lead to wear and tear, safety risks, and inconvenience during operation. At the same time, the increasing focus on renewable energy sources has encouraged the use of solar power for sustainable EV charging solutions. Wireless power transfer combined with solar energy and smart authentication offers a promising alternative for future charging infrastructure.

This paper presents the design and development of a Solar Based Wireless EV Charging Station with RFID Authentication. The proposed system uses a solar panel to generate electrical energy, which is stored in a battery through a charge controller. Wireless power transfer is used to charge the EV without physical connectors, while RFID authentication ensures that only authorized users can access the charging facility. A microcontroller controls the overall operation of the system, including user verification, relay switching, and power transfer. The developed prototype demonstrates a safe, efficient, and user-friendly charging solution that can be extended for smart charging stations, parking areas, and future infrastructure.

**KEYWORDS:** Electric Vehicle, Wireless Charging, Solar Energy, RFID Authentication, Microcontroller, Renewable Energy

## I. INTRODUCTION

The transportation sector is undergoing a major transformation due to rising fuel prices, depletion of fossil fuels, and increasing environmental concerns such as air pollution and global warming. Electric vehicles (EVs) have emerged as an effective solution to reduce dependency on conventional internal combustion engine vehicles and to promote clean and sustainable transportation. However, the widespread adoption of EVs depends heavily on the availability of safe, reliable, and convenient charging infrastructure.

Conventional EV charging methods rely on physical cables and connectors, which can cause issues such as mechanical wear, electric shock hazards, and inconvenience in outdoor or harsh environments. Wireless EV charging, based on electromagnetic induction, eliminates physical contacts and improves safety and ease of use. In addition, integrating solar energy with EV charging stations helps reduce the load on the electrical grid and promotes the use of renewable energy. This project focuses on the design and development of a Solar Based Wireless EV Charging Station with RFID Authentication, providing a secure, eco-friendly, and user-friendly charging solution for electric vehicles.

## II. LITERATURE REVIEW

Several researchers have investigated electric vehicle charging systems with the aim of improving safety, efficiency, and user convenience. Earlier studies mainly focused on conventional wired charging methods, which, although effective, suffer from issues related to connector wear, safety, and maintenance. With advancements in power electronics and wireless power transfer technologies, many researchers have proposed contactless charging systems based on electromagnetic induction for short-range EV charging applications. These systems offer improved safety and reduced maintenance requirements.

In recent years, the integration of renewable energy sources such as solar power with EV charging stations has gained significant attention. Solar-based charging systems help reduce dependency on grid power and support sustainable energy usage. Additionally, RFID-based authentication systems have been widely used in access control and payment systems to ensure secure and authorized usage of facilities. The existing literature shows that combining wireless charging, solar energy, and RFID authentication can result in an efficient, secure, and future-ready EV charging solution, while still offering scope for improvements in efficiency, monitoring, and automation.

### III. METHODOLOGY

The proposed system consists of a solar power generation unit, energy storage unit, wireless power transfer unit, RFID authentication system, and a microcontroller-based control unit. The solar panel converts solar energy into electrical energy, which is regulated and stored in a battery using a solar charge controller. When a user presents a valid RFID card, the microcontroller verifies the authentication and activates the charging process by switching the relay.

After successful authentication, power is supplied to the wireless transmitter coil, which transfers energy to the receiver coil through electromagnetic induction. The received power is then used to charge the EV battery or a demonstration load. The entire system is tested in both individual module mode and integrated mode to verify proper operation, efficiency, and reliability of the charging process.

### IV. HARDWARE DESCRIPTION

The hardware of the proposed system is centered around a microcontroller, which controls the overall operation of the charging station, including RFID authentication, relay control, and system monitoring. A solar panel is used as the primary energy source, and a solar charge controller regulates the charging of a rechargeable battery to ensure safe and efficient energy storage. The RFID module is used to authenticate users before allowing access to the charging system, thereby improving security and controlled usage.

For wireless charging, a transmitter coil and receiver coil are used to transfer power through electromagnetic induction. A relay module is used to switch the power supply to the wireless charging unit based on the microcontroller's control signals. An LCD or indicator unit can be included to display system status such as authentication result and charging status. The overall hardware setup is compact, reliable, and designed for easy expansion in future.

### I. RESULTS AND DISCUSSION

The developed EV charging station prototype was tested under normal operating conditions. The solar panel successfully generated electrical energy and charged the battery through the charge controller. The RFID authentication system correctly identified authorized and unauthorized users, allowing charging only for valid cards. The wireless power transfer unit was able to transfer power efficiently over a short distance, and the charging process started and stopped as expected based on control commands.

The results confirm that the system operates reliably and safely for basic EV charging applications. The integration of solar energy, wireless charging, and RFID authentication improves user convenience, safety, and energy efficiency, making the system suitable for educational and small-scale practical implementations.

### HARDWARE FIGURES

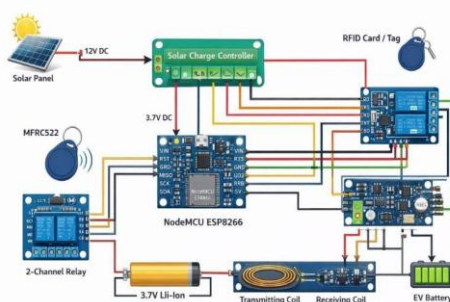

**Fig 1. Circuit Diagram of Solar based Wireless EV charging Station**

The system consists of a solar panel connected to a solar charge controller that charges a 3.7 V Li-ion battery and powers the NodeMCU ESP8266 controller. An RFID module is used for user authentication, and upon successful verification, a relay activates the wireless power transfer unit, which transfers energy from the transmitting coil to the receiving coil to charge the EV battery safely and wirelessly.



Fig 2. NodeMCU ESP8266

The NodeMCU ESP8266 is a low-cost microcontroller with built-in Wi-Fi used as the main control unit of the system. It processes inputs from sensors/modules, controls relays and other devices, and can also enable wireless communication for monitoring or control applications.

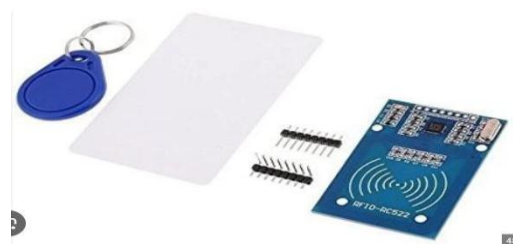

Fig 3. RFID authentication Unit

The RFID authentication unit is used to provide secure and controlled access to the charging station. Each authorized user is provided with an RFID card or tag. In this system, a commonly used RFID reader module such as **MFRC522** is employed, which operates at a **supply voltage of 3.3 V** and typically consumes around **20 to 30 mA of current** during operation.



Fig 4. Wireless Power Transfer Unit

This module consists of a transmitting coil and a receiving coil used for wireless power transfer based on electromagnetic induction. The transmitter sends power without physical contact, and the receiver captures this energy to charge the battery or power the load safely and conveniently.



**Fig 4. 2-channel relay module**

The 2-channel relay module is used to switch high-power circuits using low-power control signals from the microcontroller. In this system, it controls the power supply to different sections such as the wireless charging unit, ensuring safe and controlled operation.



**Fig 5. Power flow and control Flow Diagram**

In the proposed system, the power flow starts from the solar panel, passes through the charge controller, and is stored in the battery. From the battery, power is supplied to the control unit and other modules. When a valid RFID card is detected, the NodeMCU activates the relay, which supplies power to the transmitting coil. Wireless power is then transferred to the receiving coil and used to charge the EV battery.

## II. CONCLUSION

The Solar Based Wireless EV Charging Station with RFID Authentication successfully demonstrates a safe, efficient, and eco-friendly approach to electric vehicle charging. The system eliminates physical connectors through wireless power transfer, utilizes renewable solar energy, and ensures secure access using RFID technology. This project provides valuable practical exposure to renewable energy systems, embedded systems, and power electronics, and it can serve as a foundation for future smart EV charging infrastructure.

### III. FUTURE SCOPE

Future enhancements of the system may include IoT-based remote monitoring of charging status, mobile application integration, billing and payment systems, higher power wireless charging, and fast-charging techniques. The system can also be extended with battery health monitoring, smart grid integration, and autonomous vehicle docking for fully automated EV charging stations.

### REFERENCES

**(You can keep or modify these; I can also tailor them exactly to your project)**

1. S. Y. Hui, W. Zhong and C. K. Lee, "A Critical Review of Recent Progress in Mid- Range Wireless Power Transfer," IEEE Transactions on Power Electronics, vol. 29, no. 9, pp. 4500–4511, 2014.
2. M. Budhia, G. A. Covic and J. T. Boys, "Design and Optimization of Circular Magnetic Structures for Lumped Inductive Power Transfer Systems," IEEE Transactions on Power Electronics, vol. 26, no. 11, pp. 3096–3108, 2011.
3. A. Kurs et al., "Wireless Power Transfer via Strongly Coupled Magnetic Resonances", Science, vol. 317, no. 5834, pp. 83–86, 2007.