

# DESIGN AND IMPLEMENTATION OF SMART SHOPPING CART WITH REAL-TIME PAYMENT AND E-RECIPT GENERATION

Alluru Komali<sup>1</sup>, Pachipala Reddy Preetham<sup>2</sup>, DS Jaipal Reddy<sup>3</sup>, Pogaku Salma<sup>4</sup>, M Revathy<sup>5</sup>

<sup>1-4</sup>UG Students, Dept. of ECE, JNTUA College of Engineering Kalikiri, Andhra Pradesh, India

<sup>5</sup>Assistant Professor (Adhoc), Dept. of ECE, JNTUA College of Engineering Kalikiri, Andhra Pradesh, India

\*\*\*

**Abstract** – The usual billing procedure within most retail outlets remains a centralized check out point where the customers have to endure long queues in order to make a purchase. This usually causes inconvenience, long queues and unsatisfactory shopping experience particularly during peak time and very populated shopping malls. This issue gains more importance as the urban areas grow and the number of consumers grows requiring a more efficient and automated solution. Due to the fast development and mass usage of Internet of Things technology, there is an opportunity to change the traditional shopping process into a smart and more convenient one. The paper demonstrates the conceptual design of a smart shopping cart system that incorporates the use of the IoT technology to automate the payment process itself in the cart. The suggested system provides the possibility to monitor the products in real-time when they are being added to or removed from the cart. All objects are spotted in terms of barcode scanning and related information, e.g. cost and quantity, are automatically updated. The smart cart in effect keeps on estimating the overall price of the chosen purchases and shows the price to the customer in real time, thus removing the possibility of manual payments by billing machines. This not only ensures that it eliminates the need to rely on human intervention but also minimizes the errors that are characterized by the traditional billing systems. The system also improves the levels of transparency, as the customer can track his or her expenditure during the shopping process. The main task related to this approach is to make the checkout process much easier and faster, minimize the number of people in billing counters, as well as to enhance customer satisfaction in general. In addition, the paper talks about system architecture, the methodology, and the working flow of the proposed smart shopping cart and how it can transform the way people shop in the retail stores by automating and designing the system in an intelligent way.

**Key Words:** Smart Shopping Cart, Internet of Things, Automated Billing, E-Receipt, Retail Technology, Stock update, Theft-Control, Smart Retail.

## 1. INTRODUCTION

Shopping malls and supermarkets still use the old-fashioned systems of billing when a customer has to wait till the end of the shopping to pay. This has the negative effect of creating a lengthy queue, more waiting time and inconvenience to the

customers particularly during the peak times. It is also a heavy burden on the billing workers, which causes inefficiencies and possible mistakes. These obstacles demonstrate that a more sophisticated and automated billing system is essential to alleviate customer experience at the same time increasing the efficiency of operation. As the Internet of Things has been growing rapidly, the new opportunities have become accessible to convert the ordinary retail systems into smart and automated space. IoT facilitates a smooth interaction among the devices, and the processing of data can be performed in real-time without the participation of many people. Applying the IoT to the shopping cart in relation to the retail business will allow transforming the shopping experience to a new level of complete automation of identifying products, calculating their prices, and sending bills immediately. The smart shopping cart system suggested is meant to deal with these shortcomings with technologies being added like barcode scanning, microcontrollers, and wireless communication. This system enables the clients to scan the goods as they shop, constantly update the total bill and makes real time payment with e-receipt printing. The system will increase the level of convenience in the retail industry by eliminating the use of customers waiting in queues during checkout, decreases the workload of the staff and increases the overall efficiency of the retail business.

## 2. RELATED WORK

A number of studies have been conducted on the automation of retail to enhance efficiency of the shopping and billing. Most of these research works concentrate on technologies including RFID or Radio Frequency Identification, scanning that uses bar codes and shopping solutions that use mobiles. RFID systems have the ability of automatic product identification through the attached RFID tags on the items whereby carts or billing system can sense numerous products simultaneously without necessarily having to scan them manually. Likewise, the barcode-based will be reading the details of the products with handheld scanners or an integrated device, which is processed to produce the bills. Instead, mobile shopping apps can enable the customer to scan the product with their smartphone and maintain their shopping carts online. Although these methods save so much in terms of manual labour and make the billing faster, they also have some limitations. Examples of RFID systems include the installation of special tags and readers that render the

deployment more complex and expensive. Systems involving bar codes, though cheaper, still need active user involvement in the scanning of individual products, which is not always developed. Solutions based on mobile are susceptible to the level of interaction with users and compatibility with mobile phones, hindering their use by all consumers. Moreover, most of the current systems are associated with sophisticated architectures and need serious infrastructure adjustments in the retailing settings. These aspects may make it difficult to have large-scale adoption, particularly with small and medium-sized supermarkets. Thus, a cheaper, convenient, and efficient smart shopping cart system reducing the effort of the user to the bare minimum and allowing it to support real-time and accurate billing is necessary.

### 3. PROBLEM STATEMENT

The conventional billing system followed in various supermarkets causes customers to wait in a long queue at the billing counter. This is a time-consuming process and may cause errors in billing during peak hours when a large number of customers are shopping in these stores. Customers are not able to track their expenses in real time during shopping in these stores. There is a need for a smart shopping cart system to automate the shopping process by scanning the products in real time and generating bills accordingly.

### 4. PROPOSED SYSTEM

The proposed smart shopping cart system will help to improve the experience in the entire shopping process by incorporating the automation in the supermarket setting, the real-time track mechanism, and easy navigation. The system has smart aspects that help the customers on the shopping process, that is selecting the products, up to making the final payment. The primary features of the system include the possibility to locate products of interest with the help of the digital map or navigation system. This contributes to the time that they save in searching what they need and it enhances the shopping efficiency, particularly in the big stores. Besides being able to navigate, the smart cart also has a barcode scanning system which enables the customer to scan the products they place directly in the cart. After the scanning, product information including the name price and quantity is automatically stored and shown in the interface of a cart. This is because the system is updated constantly to show the amount the customer has spent so far, and this enables them to monitor their bill and expenditure during the shopping process. In addition, the suggested system is in favour of the instant billing and payment features. After the shopping is closed, the sum can be paid directly by accounted digital payment systems without any experience of long checkout lines. Once this is successfully paid, an electronic receipt (e-receipt) is produced and delivered to the customer by use of email technology or through a mobile application. Comprehensively, the system would provide a smooth and efficient and convenient shopping experience and less manual labour and enhance store functions.

## 5. IMPLEMENTATION OVERVIEW

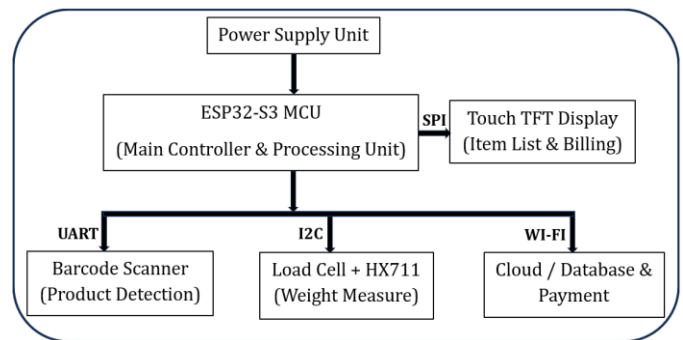

Fig -1: System Architecture Diagram

The initial part of intelligent application of shopping cart is dedicated to experimentation of the concept of the system.

Hardware components: Waveshare ESP32-S3-7-inch capacitive touch display, Waveshare barcode scanner module(c), Load cell, HX711 amplifier and power source.

Software Module: Arduino IDE

The backend of the software module consists of a web-based admin portal created using HTML, CSS, and JavaScript. The admin portal is integrated with Google Firebase, which acts as an intermediate cloud database between the smart shopping cart and the admin portal.

At this stage, system is implemented at the bare bones stage to ensure that it is able to scale up to a large scale as compared to commercial usage.

## 6. HARDWARE COMPONENTS

### 6.1. ESP32-S3-7-inch Capacitive touch display



Fig -2: ESP32-S3-7-inch Capacitive touch display

ESP32-S3 7-inch capacitive touch display is the main controller and user interface for the smart shopping cart system. It is equipped with the ESP32-S3 dual-core Xtensa LX7-based MCU running up to 240 MHz, which provides high

processing performance for real-time operations. It is capable of supporting graphics libraries such as LVGL, allowing smooth graphical user interface operations and local data processing without the need for any external controller. It is equipped with a 7-inch capacitive touch display with a resolution of 800 × 480 pixels. It is also equipped with IoT connectivity features such as 2.4 GHz Wi-Fi and Bluetooth 5 connectivity, which enables smooth communication with cloud environments, store servers, and databases. It is also equipped with UART, SPI, and I2C communication interfaces to connect peripherals such as barcode scanners. It is compatible with the Arduino IDE and is powered by low voltage. It efficiently manages the operations of the product display, billing updates, and communication with the software backend for the smart shopping cart system.

### 6.2. Barcode scanner module

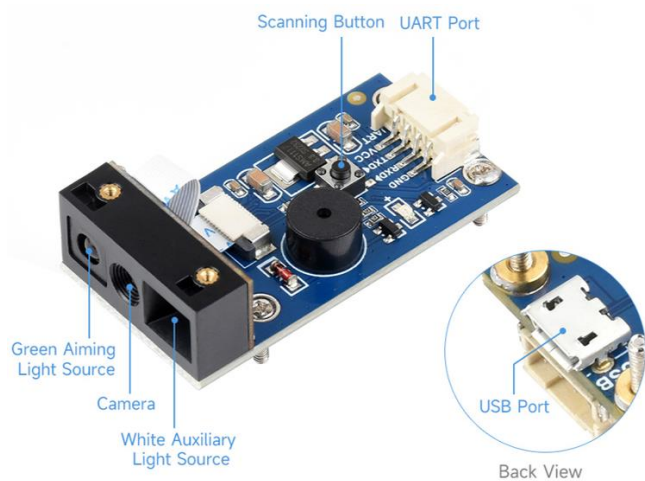

Fig -3: Barcode scanner module

The barcode scanner module is used in the smart shopping cart system to ensure the accurate and quick scanning of the product. It is capable of scanning one-dimensional and two-dimensional codes with high accuracy.

### 6.3. Load Cell

Load cell converts mechanical force like tension or compression into a measurable electrical signal. It works by using strain gauges bonded to a metal body that deforms slightly under load. This deformation changes electrical resistance which then converted into a voltage signal proportional to weight. Measures real-time weight variation of items placed in the cart for product verification. Enhances billing accuracy by validating scanned items through weight-based confirmation.

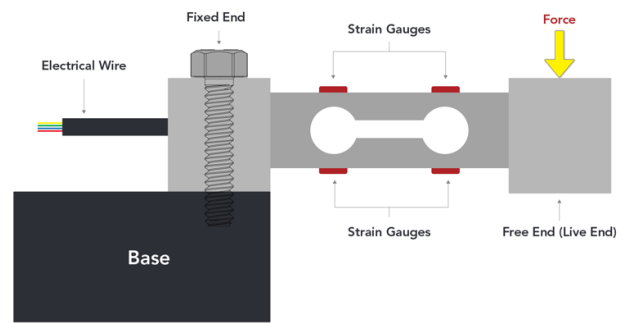

Fig -4: Load Cell

### 6.4. HX711 amplifier

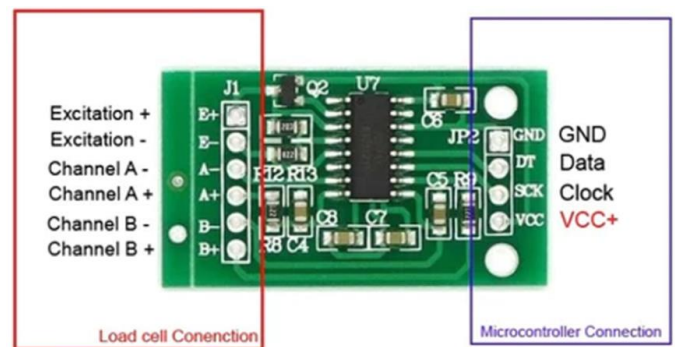

Fig -5: HX711 amplifier

The HX711 amplifier module is employed in the smart shopping cart system for connecting the load cell to the controller. The module amplifies the weak analog signal from the load cell and converts it to digital data for the ESP32-S3 microcontroller. The module has a precise 24-bit analog-to-digital converter for enhanced precision. The HX711 amplifier module amplifies the weak signal from the load cell and converts it to digital data for the ESP32-S3 microcontroller.

### 6.5. Power Supply

The system operates using low-voltage embedded electronics. A regulated 3.3V to 5V DC supply is required to power the ESP32-S3, display, and peripheral modules. A 5V 2A power supply is recommended to provide a safety margin and stable operation of the system during shopping.

**Table -1:** Components Table

Component	Specification	Function
ESP32-S3 microcontroller	32-bit microcontroller	Controls the entire system
Integrated touch display	Capacitive 7-Inch display	User interaction
Barcode scanner module	Serial scanner	Reads product barcode
Load Cell	5Kg capacity	Measures product weight
HX711 Amplifier	24-bit ADC	Converts load cell signal

### 7. SOFTWARE IMPLEMENTATION

The software part of the smart shopping cart system is implemented using the Arduino Integrated Development Environment to program the ESP32-S3 microcontroller. The firmware controls all the peripherals, such as the barcode reader, load cell, and touch display. The system will communicate with the backend database hosted on Google Firebase using Wi-Fi connectivity. The database will contain information such as product ID, product name, and product cost. After retrieving information on the product, the system will display product information on the touch display. The system will also update the total cost in real time. A graphical user interface is created on the touch display to display information on scanned products, total cost, and system status. In addition, a web-based interface is created to allow administrators to update product information on the database hosted on Google Firebase. This will allow real-time updating of information on the database, ensuring efficient real-time billing for the smart shopping cart system.

### 8. METHODOLOGY

The smart shopping cart follows a very straightforward step by step way of work. Firstly, when the power is turned ON, the display gives the acknowledgement that the system is online. A static navigation map is provided to find the location of products in the store. The goods are selected and scanned with the assistance of barcode scanner, then the items are placed into the cart. The scanned data is sent to the controller, which retrieves the product details stored in the database. The system automatically identifies the weight of the products using load cell and HX711 amplifier. The microcontroller compares the product weight in the cart with the database, if there is any mismatch then checkout button on the display will be disabled else the customer can continue shopping. The whole bill is calculated and the payment QR code is displayed on the screen, after successful payment another QR code is generated to download e-receipt. All the transactions are saved in admin portal along

with the instant stock update in firebase. The process will remove various scanning operations at the checkout points and will give hype shopping experience and passion.

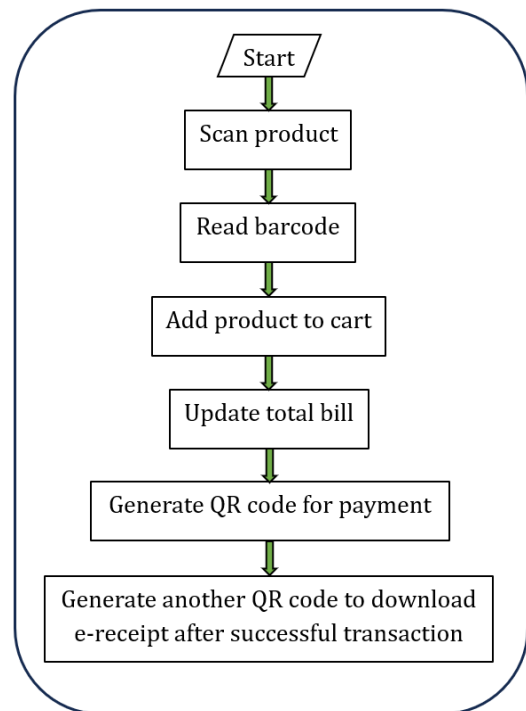

**Fig -6:** Flow chart of system operation

### 9. RESULTS AND DISCUSSION

The proposed Smart Shopping Cart System is successfully designed and implemented to ensure the functionality, reliability, and real-time performance of the proposed system. It is designed to integrate the IoT-based hardware, cloud connectivity, and sensor-based validation to ensure the development of the proposed system. It is developed to ensure the accurate performance of the product identification, billing, and digital payment processes while maintaining the data consistency with the cloud backend using Firebase.

The following results ensure the performance and functionality of the proposed system:



**Fig -7:** Project setup

➤ System initialization and Boot process

The proposed system is successfully designed to ensure the ON process and initialization of the hardware components. It displays the welcome message followed by the Wi-Fi and cloud connectivity messages.



**Fig -8:** Initial screen

➤ Successful Wi-Fi and Cloud Connectivity

The system successfully establishes a connection with the Wi-Fi network. Moreover, it synchronizes in real-time with the cloud database. The "System Online" status confirms the readiness of the system for operation.

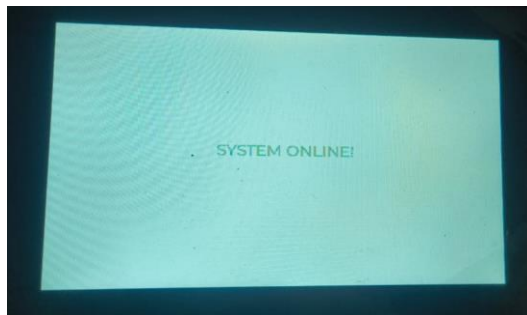

**Fig -9:** System Online screen

➤ Display of Promotional Offers

The user interface successfully displays the dynamic promotional offers. Thus, it engages the user. Moreover, it serves as a real-time marketing feature for the system.

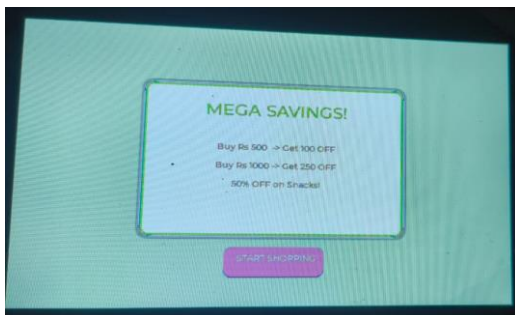

**Fig -10:** Advertisement screen

➤ Store Navigation Interface Functionality

The navigation interface successfully displays a static map of the store layout. Thus, the user can easily identify the location of the products.

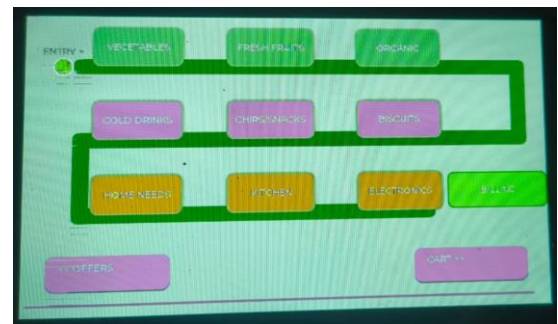

**Fig -11:** Static Store Navigation screen

➤ Accurate Barcode-Based Product Identification

The system successfully identifies the products by scanning the barcode. Moreover, it retrieves the required information from the cloud database. The scanned products are successfully added to the cart interface.

➤ Real-Time Cart Management System

The system successfully updates the cart in real-time. Moreover, the user can add or remove items from the cart through the on-screen interface. The total amount is calculated in real-time.

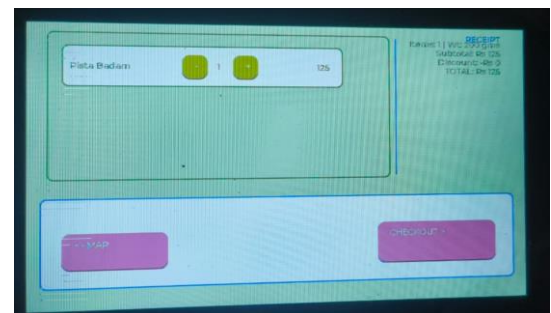

**Fig -12:** Cart interface

➤ Effective Weight Verification Mechanism

The load cell successfully integrates with the HX711 Load Cell Amplifier Module. Moreover, it accurately calculates the weight of the items in the cart. The system successfully verifies the weight of the products by comparing it with the available data.

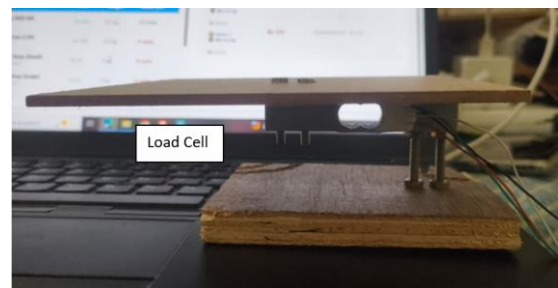

**Fig -13:** Load Cell setup

➤ Mismatch Detection and Anti-Theft Functionality

The system successfully detects the mismatch in weight. Thus, it disables the check-out option. The anti-theft feature prevents unauthorized operations in the system.

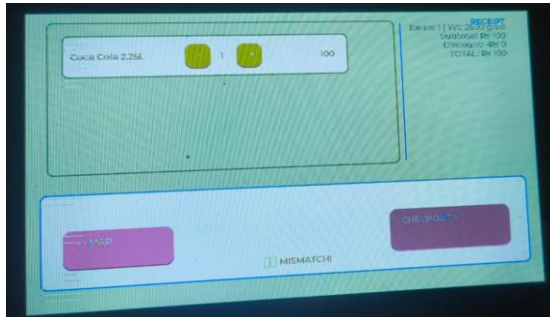

Fig -14: Cart mismatch, checkout disabled

➤ Automatic Revalidation and Recovery

Once the correct object is inserted into the basket, the process again verifies the weight and re-enables the checkout option. This process is uninterrupted and user-friendly.

➤ QR Code-Based Payment System

The system will create a QR code with the amount payable on the bill, facilitating the payment through the UPI apps.

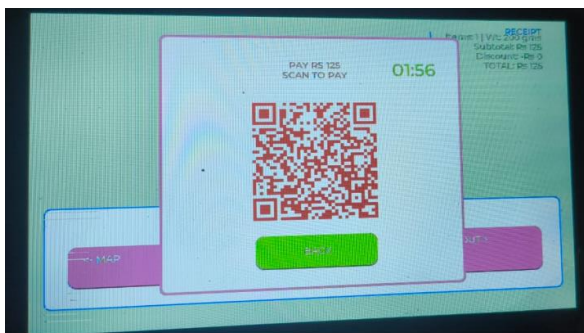

Fig -15: QR Code for payment

➤ E-Receipt Generation and Download

A second QR code is generated for the purpose of downloading the receipt after the payment is made.

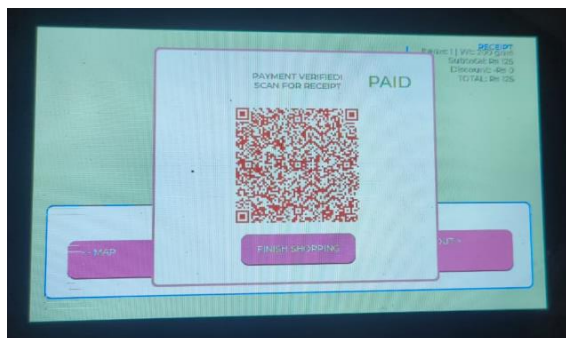

Fig -16: QR Code for e-receipt

➤ Real-Time Cloud Data Storage and Synchronization

All the information related to the transaction, including the bill ID, items purchased, and the amount, is stored on the cloud database with the help of Firebase.

➤ Automatic Inventory Management

The system also keeps track of the stock level of the products in real time, i.e., after every transaction.

Smart Trolley Dashboard

**Inventory Management**

Product Name	Price (Rs)	Stock Quantity	Weight (kg)
Godrej Soap (Small)	Rs 45	0 kg	0 units
Godrej Soap (Large)	Rs 85	0 kg	0 units
Haldiram	Rs 5	0.05 kg	0 units
Campa 1L	Rs 40	0 kg	0 units
Maggi Noodles	Rs 100	0 kg	96 units
Basmati Rice 5kg	Rs 500	1 kg	397 units

**Recent Transactions**

Bill ID & Count	Total Amount	Items Purchased
ID: DEMO-79003 Name 3 Wt: 3 kg	Rs 1250	Basmati Rice 5kg (x3) - Rs 1500
ID: DEMO-29003 Name 4 Wt: 400 kg	Rs 400	Maggi Noodles (x4) - Rs 400
ID: DEMO-56138 Name 7 Wt: 3500 kg	Rs 3250	Basmati Rice 5kg (x7) - Rs 3500
ID: DEMO-128216 Name 1	Rs 400	Basmati Rice 5kg (x1) - Rs 500

Fig -17: Inventory management

The experimental results prove that the Smart Shopping Cart system is working efficiently with high accuracy in the identification, billing, and validation processes. The integration of IoT, cloud computing, and sensor-based verification is ensuring the security, reliability, and user-friendliness of the system.

## 10. CONCLUSIONS

The proposed system is based on the idea of developing an IoT-based smart shopping cart for the purpose of automating the billing process in retail supermarket stores. It is designed to reduce the dependency on the checkout counters for billing purposes. It provides the functionality to scan the items, calculate the price, and verify the weight of the products directly on the shopping cart. It enables the customer to scan the products during the shopping process, which reduces the time required to wait in the queue at the checkout counter. It provides the benefits of digital payment and the generation of e-receipts. It can be integrated with the cloud database for the purpose of real-time product monitoring. It can be further developed to incorporate advanced features in the future to support the development of smart shopping environments.

## 11. FUTURE SCOPE

- Artificial Intelligence-Based Product Recommendation: The integration of artificial intelligence may help in recommending products to customers based on their needs and preferences.
- Computer Vision for Automatic Product Detection: The integration of computer vision may help in removing the need for scanning products by allowing the camera to identify the products and add them to the cart.
- Mobile Application Integration: The development of a mobile application may help customers access the cart and make payments.
- Advanced Payment Methods (NFC & Digital Wallets): The future version of the application may include multiple payment options such as near-field communication-based payment systems and digital wallets for efficient payment processing.
- Real-Time Indoor Navigation System: Technologies such as Bluetooth beacons can help in implementing a real-time indoor navigation system, which can help in directing customers to the location of the required product in a more efficient manner.

## REFERENCES

- [1] Aishwarya Giri, Darshana Bawane, Mrunmayi Kalejwar, Shrutika Mahalle, Tejshree Tekade, Dr. Swati Dixit, "Automatic Smart Shopping Trolley with Billing", Vol. 10, Issue 12, Dec 2023 IRJET-V10I1233.
- [2] Mr. M. Balaji Naiak, K. Akhila, U.L.S.M. Mouli, M.V.V. Avinash, G. Dileep, K. Abhihaas, "Tech Enhanced Shopping Trolley", Vol. 11, Issue 03, Mar 2024 IRJET-V11I3127.
- [3] M. Shyamsunder, Sambaraju Bhavani, Mohammed Mujtaba, Mikkili Keerthana, "Smart Billing Trolley", Vol. 08, Issue 07, July 2021 IRJET-V8I7182.
- [4] T. Thirumoorthy, S. Roshan Prakash, S. Surendran, T. Thenmozhi, "Smart Trolley with Automated Billing System", Vol. 06, Issue 03, Mar 2019 IRJET-V6I31127.
- [5] Savita C Teli, "Design of an IoT based Smart Trolley Prototype for Retail Mart", Vol. 07, Issue 12, Dec 2020 IRJET-V7I1297.
- [6] Pritha N, Sahana S, Selvin Stephy N, Shiny Rose S, Unnamalai S, "Smart Trolley System for Automated Billing using RFID and IoT", Vol. 05, Issue 04, Apr 2018 IRJET-V5I444.
- [7] Chukwuka Michael, Akatobi Daniel, Chinedu Onyeka, Onyeka Chidera, "Design and Implementation of a Light Fidelity Based Automated Smart Trolley", Vol. 10, Issue 05, May 2023 IRJET-V10I5199.
- [8] Thiyagarajan.M, Aejaz.M, Kumar.M, "Smart Shopping Trolley", Vol. 07, Issue 04, Apr 2020 IRJET-V7I4278.
- [9] Anitha G, Dr. Subburam S, Keerthana K, H Yoganandarajurs, "IoT-Based Intelligent Shopping Cart to Enhance the Shopping Experience", Vol. 09, Issue 12, Dec 2022 IRJET-V9I12118.

- [10] Ghatol Sonali Digambar, Mrs. V.S. Jahagirdar, Pratiksha Dattatraya Khamitkar, "Smart Shopping Using Smart Trolley", Vol. 05, Issue 05, May 2018 IRJET-V5I5452.
- [11] Om Ravi Mhaskar, Aditya Sandip Benichetake, Arjun Amar Dalvi, Shrivardhan Rajesh Chavan, "Automatic Human Follower Shopping Trolley", Vol. 08, Issue 01, Jan 2021 IRJET-V8I1300.
- [12] P. Seema, M. Shalini, R. Sindhu, "Smart Shopping using Smart Trolley", Vol. 05, Issue 03, Mar 2018 IRJET-V5I3642.
- [13] Tejal Deshpande, Karan Singh, Karan Parmar, "RFID based Smart Trolley using ARM Processor", Vol. 04, Issue 04, Apr 2017 IRJET-V4I4621.
- [14] Mohammed Mujtaba, Mikkili Keerthana, "Smart Billing Trolley", Vol. 08, Issue 07, July 2021 IRJET-V8I7182.
- [15] M. Thiyagarajan, M. Aejaz, M. Kumar, "RFID Based Advanced Shopping Trolley for Super Market", Vol. 04, Issue 07, July 2017 IRJET-V4I7413.

## BIOGRAPHIES



**Ms. Alluru Komali** is currently student from Department of Electronics and Communication Engineering from JNTUA College of Engineering Kalikiri, Andhra Pradesh, India



**Mr. Pachipala Reddy Preetham** is currently student from Department of Electronics and Communication Engineering from JNTUACEK, AP, India



**Mr. DS Jaipal Reddy** is currently student from Department of Electronics and Communication Engineering from JNTUACEK, AP, India



**Ms. Pogaku Salma** is currently student from Department of Electronics and Communication Engineering from JNTUACEK, AP, India



**Mrs. M. Revathy** Assistant Professor (Adhoc) at JNTUACEK from Department of Electronics and Communication Engineering, AP, India