

# GEARLESS TRANSMISSION SYSTEM USING ELBOW MECHANISM

Shreyash Jagtap<sup>1</sup>, Sai Salunkhe<sup>2</sup>, Shubham Gurav<sup>3</sup>, Adinath Khumbhar<sup>4</sup>, Sameer Yewale<sup>5</sup>

<sup>1-4</sup>Student[Department of Mechanical Engineering KBP Polytechnic Satar, Maharashtra, India

<sup>5</sup>Professor, Dept. of Mechanical Engineering, Kbp Polytechnic Satara, Maharashtra, India

\*\*\*

**Abstract** - The gearless transmission system, which utilizes an "elbow" mechanism, is intended to provide a system for the transmission of rotary motion without gears. In a gearless transmission system, a number of "elbow" mechanisms are connected to a turning disc and a number of output shafts, where the "elbow" mechanisms are connected to each other to form a circular path when the input shaft rotates, causing the output shaft to turn simultaneously.

The gearless transmission system utilizing an "elbow" mechanism is simple in design, easy to manufacture, and requires minimal maintenance compared to other gear systems. This system is ideal for use in a number of mechanical and industrial applications due to the low costs and high efficiency of the system in the transmission of motion to a number of shafts for simultaneous rotation.

**Key Words:** 1.Gearless transmission, 2.Elbow mechanism, 3.Powertransmission,4.Mechanical linkage,5.Rotary motion, 6.Machine design,7.Automation systems.

## 1. INTRODUCTION

One of the most important functions of a mechanical system is the transmission of power, which is responsible for the transmission of motion from one point to another in the system. Generally, mechanical systems use gears for the transmission of motion from one shaft to another. Gears are effective for the transmission of power from one point to another in a mechanical system. However, there are many disadvantages of using gears for the transmission of power from one point to another in a mechanical system. The disadvantages of gear transmission include complexity, higher cost, and the production of noise during the transmission of motion from one point to another in a mechanical system.

To overcome the disadvantages of gear transmission in a mechanical system, a gearless power transmission system with an elbow mechanism is developed. In the gearless power transmission system with an elbow mechanism, there is no need for the use of gears for the transmission of motion from one point to another in the system. The transmission of motion from one point to another in the gearless power

transmission system with an elbow mechanism is done with the help of an elbow mechanism that is simple and consists of L-shape rods that rotate with the help of a rotating disc.

## 2. LITERATURE SURVEY

The gearless transmission systems use a system of transferring rotary motion without gears; for example, using an elbow-shaped linkage system that rotates a disc and multiple output shafts for simultaneous rotation [2]. The elbow linkage system is simple and easy to manufacture; the input shaft rotates the elbow rod in a circular motion for the output shafts to rotate simultaneously without gear meshing [5]. The advantages of the gearless transmission system are that it is cheap to make and maintain [4]; the system can be used for synchronized shaft rotation in various manufacturing processes and conveyors [2]. The system is adaptable for use in various loads [5]; however, the system has limitations when compared to a gear system in terms of torque and speed [1].

## 3. METHODOLOGY

The project was completed in a step-by-step fashion. Firstly, the drawing of the project, which included the top view, front view, and side view, was studied. This was to comprehend the arrangement of all the parts, such as the shafts, motor, bearings, and elbow rods.

Then, materials were selected for the project. For example, mild steel was used for the shafts, metal rods were used for the elbow links, and square pipes were used for the frames. Then, all the parts were fabricated based on the given dimensions.

After fabrication, the project was assembled. This included mounting the motor, fixing the shafts along with bearings, and inserting the elbow rods into the hub. Proper alignment was maintained to ensure smooth working of the project. Then, the project was tested by running the motor. The project was successfully able to transmit motion from one shaft to another through the use of an elbow mechanism. Lastly, the project was checked to ensure smooth working, minimum noise, and efficiency. Some adjustments were made to ensure smooth working.

4. SYSREM DESIGN AND COMPENENT DESCRIPTION

TABLE 4.1:-Component Description

Sr. No	Component Name	Material Used	Function
1.	Input Shaft	Steel	Transfers input rotational motion
2.	Rotating Disc	Steel	Connects elbow rods and rotates with input shaft
3.	Elbow Rods	Steel	Transmits motion to output shafts
4.	Output Shafts	Steel	Receives motion from elbow rods
5.	Bearings	Standard Ball Bearing	Supports smooth rotation
6.	Frame Structure	Steel	Holds all components together

The gearless transmission system that uses an elbow mechanism has key parts that work together to make motion transmission smooth and efficient.

The input shaft gets motion from the motor and is the main part that drives the system. This motion is then passed on to the rotating disc, which is attached to the shaft and spins with it. The rotating disc is like a base that connects to the elbow rods and helps turn motion into motion that uses links.

The elbow rods are L-shaped steel links. Do the main work, in the system. They send motion from the rotating disc to the output shafts by sliding and rotating. The output shafts get this motion. Spin accordingly which is the final output.

Bearings are used to support the shafts so they can spin smoothly and without friction. All these parts are attached to a frame that holds them in place keeps them aligned and provides stability when the system is working.

The frame is important because it keeps everything and in line. The elbow rods, rotating disc and shafts all work together to make the system run smoothly. The bearings help reduce friction, which makes the system more efficient.

Overall the gearless transmission system using an elbow mechanism is made up of important parts that work together to provide efficient motion transmission. The system relies on the movement of its parts to achieve smooth and efficient operation.

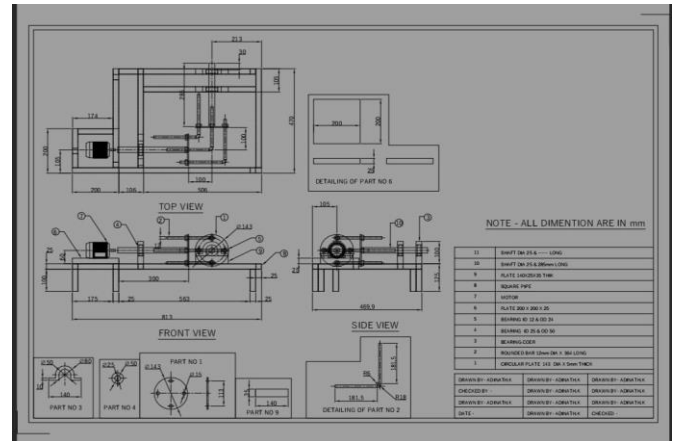

FIG 4.1:-2D Drawing

drawing shows the design of a gearless transmission system using elbow mechanism with top, front, and side views. All dimensions are given in millimeters for proper fabrication. The system includes a motor connected to the input shaft, which drives a circular plate (hub) mounted on the shaft.

Elbow rods are connected to the plate, which transmit motion to the output shaft placed at 90°, showing gearless motion transfer. Bearings are used to support the shafts and reduce friction for smooth operation. The entire system is mounted on a frame structure made of square pipes and plates to maintain alignment and stability.

The drawing also provides details of individual parts, helping in accurate manufacturing and assembly of the system

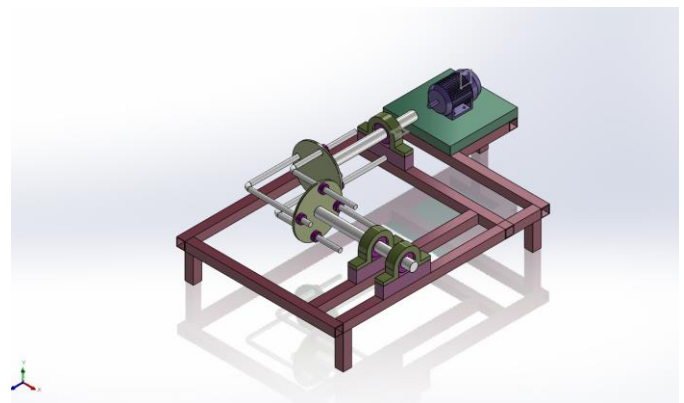

FIG 4.2:-3D Model

The 3D model is a gearless transmission system. It uses an elbow mechanism that is mounted on a frame. This system has a motor that is connected to the input shaft. When the electric motor runs it makes the input shaft rotate. The input shaft is supported by bearings so that it can move smoothly. There is a plate, which is like a disc, fixed on the input shaft. Many elbow rods are connected between two of these plates. As the input shaft rotates these elbow rods move in a circle.

They transfer motion to the output shaft. The output shaft is positioned at an angle, which is 90 degrees. This shows that the gearless transmission system can transmit motion without using any gears.

The whole thing is supported by a steel frame structure. This steel frame provides stability. Makes sure all the parts are properly aligned. There are bearings, in the places where they are needed to reduce friction and make sure everything works efficiently. The design of the gearless transmission system is simple and compact. It is a way to show how gearless motion transmission works. The gearless transmission system is easy to understand. It does not take up a lot of space

## 5. ADVANTAGES AND APPLICATIONS

### Advantages

- Simple and compact design
- Low manufacturing cost
- Reduced maintenance requirements
- No need for lubrication like gear systems
- Ability to transmit motion to multiple shafts

### Applications

- Mechanical automation systems
- Small industrial machines
- Educational demonstration models
- Power transmission mechanisms
- Agricultural machinery

## 6. CONCLUSIONS

A gearless mechanism that transmits motion using a pivoting or elbow-shaped, multi-linked machine is a new twist on how to send motion from one part of a machine to another, using no gears. Traditional gear systems require a lot of parts to operate as well as time in their upkeep because they create friction, wear, and require oil or other lubricant. Using this method overcomes many of those issues by creating a linkage, providing more "efficient" power transfer with less "mechanical loss" from the transmission of force through the linking mechanism. The mechanism uses two elbow-shaped rods to convert rotation into a combination of linear and rotational motion so that power can be "smoothly" and continuously transferred from one shaft to another, even at angles up to 90°, without creating vibration or noise. A gearless transmission mechanism provides a reliable machine that requires far less maintenance than a gear style. This gearless transmission mechanism has a simplified manufacturing and assembly process compared to gear-style machines, thus making it cost-effective. It is ideal for use in light-medium duty machinery and automation and educational models with smooth, continuous power transmission

## REFERENCES

- [1] R. S. Khurmi and J. K. Gupta, Theory of Machines, S. Chand Publications, New Delhi, 2018.
- [2] Gaikwad, J. (2017). Gearless Transmission Mechanism and its Applications.
- [3] S. S. Rattan, Theory of Machines, McGraw Hill Education, India, 2017.
- [4] N. Patil, J. Gaikwad, M. Patil, and C. Sonawane, "Gearless Transmission Mechanism and its Applications," International Journal of Innovative Research in Science, Engineering and Technology, vol. 6, no. 3, 2017.
- [5] Khan, A. S., & Pandey, K. (2021). Design and fabrication of gearless transmission using elbow Mechanism. International Research Journal of Engineering and Technology.