

Electromagnetic Braking System

Siddhant Gaikwad¹, Vedant Ghadge², Chinmay Kadam³, Soham Kadam⁴, Mr. P. V. Zore⁵

^{1,2,3,4} Student, of mechanical Engineering, Karmaveer Bhaurao Patil Polytechnic Satara, India

⁵Lecturer, of Department of Mechanical Engineering, Karmaveer Bhaurao Patil Polytechnic Satara, India

Abstract - Electromagnetic braking is a modern way to stop motion that blends electrical control with mechanical action. Instead of relying only on hydraulic pressure or manual force, EMB uses an electromagnet to pull a brake shoe or pad against a rotating disc or drum.

When current flows through the electromagnet, it creates a strong magnetic field. That field acts like an invisible hand, pulling the brake shoe into firm contact with the moving surface. The moment contact happens, friction is generated, and the rotation slows down. By adjusting the current, you can fine-tune how much braking force is applied — gentle slowing or a sharp stop, all with precise control.

Unlike eddy current brakes, which are contactless and rely on induced currents in the disc, EMB does involve mechanical contact. The electromagnet is essentially the actuator, while the actual braking force comes from friction at the contact point. This makes EMB a hybrid system: electromagnetic actuation combined with mechanical braking.

Because the electromagnet replaces complex linkages or hydraulic systems, EMB setups are simpler, tougher, and easier to maintain. That's why they're trusted in trains, industrial machines, and even some cars — places where safety, reliability, and efficiency matter most.

Key Words: Electromagnetic Induction, Non-contact braking, Magnetic Field Interaction, Controlled Braking Force, Maintenance Free design, Railway Safety Systems.

1. INTRODUCTION

Electromagnetic brakes—often called EM brakes or electro-mechanical brakes—are braking systems that use magnetism to apply friction and bring motion to a stop. The principle is straightforward: when electric current flows through a coil, it generates a magnetic field. That magnetic field pulls an armature against a magnetic face, and this mechanical contact produces the braking force.

The strength of the braking action depends on the current supplied. More current means a stronger magnetic pull and greater friction, while less current gives lighter braking. This makes EMB systems highly controllable and reliable, especially in applications where smooth and precise stopping is essential.

Electromagnetic brakes have been widely adopted in trains, trams, and industrial machinery since the mid-1900s because of their dependability and efficiency. At their core, they work like any brake: converting kinetic energy into heat through friction, with that heat dissipating into the surrounding air.

While most braking systems still rely on conventional mechanical pads and hydraulics, EMB offers clear advantages—less wear, smoother control, and improved safety. These qualities make them an increasingly popular choice in modern transport and industrial equipment, where performance and reliability are critical.

2. LITRETURE REVIEW

- Electromagnetic braking systems (EMB) are emerging as efficient alternatives to conventional friction brakes, offering reduced wear, smoother operation, and enhanced safety. Foundational design principles are detailed in standard texts such as Machine Design by Khurmi & Gupta [2] and Design of Machine Elements by Bhandari [3], while Singh's Automobile Engineering and Technology provides broader context on braking system evolution [1].
- The theoretical basis of EMB lies in eddy currents, governed by Lenz's Law. Heald's work in the American Journal of Physics explains how induced currents oppose motion, enabling braking without mechanical contact [4]. Online resources further illustrate this principle [10][11][12][13][14].
- Practical applications have been demonstrated by Patel [5], Sevel et al. [6], and Puttewar et al. [7], showing improved efficiency and reliability. Industry perspectives, such as those from the Society of Automotive Engineers [8], highlight EMB's role in advanced braking technologies. Experimental studies, including Wagh et al. [9], confirm faster stopping times and reduced friction losses.
- Despite these advantages, EMB systems face limitations at low speeds. Hybrid solutions combining electromagnetic and mechanical brakes are often recommended to overcome this challenge [15].

3. WORKING PRINCIPLE

Electromagnetic brakes work by slowing a vehicle down with mechanical resistance created by electromagnetic force. They're powered by electricity, but the real stopping power gets delivered directly to the wheels.

Here's how they do it: When you hit the brakes, these systems use a magnetic field—produced by current running through a coil—to push back against the wheel's movement. This converts the vehicle's kinetic energy straight into heat. The stopping force they produce can actually dwarf the

vehicle's driving force, which means they can bring things to a halt fast, no matter how fast you started out.

What's nice about this setup is how smoothly and reliably it does the job. The process doesn't rely on the grinding friction you get with regular brakes, so there's less wear and tear. The end result? Breaking that's efficient, consistent, and lasts a lot longer.

4. METHODOLOGY

1. Project Conceptualization

This project kicked off because we really needed a better way to stop—something that wastes less energy on friction and does the job more efficiently. We threw around a bunch of options, but the Electromagnetic Braking System checked all the boxes. It's solid, it doesn't break the bank, and it fits right in with today's cars.

2. Design and Analysis

Design-wise, we zeroed in on three main components: the rotor disc, the electromagnetic coil, and the frame. The challenge? Figuring out exactly how much braking torque was necessary and picking materials that could actually handle it. We put the rotor and frame through some quick stress tests to make sure they were up to it. Mild steel made the cut for the frame because it's tough and easy to weld, while copper wire was the obvious choice for the coil because its conductivity is just hard to beat.

3. Manufacturing Process

For standard components such as bearings, fasteners, and copper wire, we sourced materials locally to keep things practical and cost-effective. The frame was built from mild steel plates, which we cut to size and welded together to form a rigid structure.

The rotor began as plain sheet metal. Through careful shaping, balancing, and surface finishing, we ensured it rotated smoothly with minimal resistance. For the electromagnet, we wound copper wire around a ferromagnetic core, applied proper insulation, and mounted it securely onto the frame using bolts.

Once all the parts were ready, we moved to final assembly. Every component was aligned with precision, since even slight misplacements could affect performance. The process demanded patience and accuracy — no shortcuts, no sloppy fits. The end result was a system that not only functioned reliably but also reflected the care and discipline put into its construction.

4. Electrical Integration

We powered the coil with a DC supply, wiring it so the magnetic field activates when needed. A simple control switch let us adjust the current, making it easy to fine-tune the braking force. To keep it safe, we used insulation and fuses—no short circuits on our watch.

5. Testing and Validation

We ran tests across different current levels, timing how quickly the rotor stopped and lining those numbers up against standard brakes. What mattered most to us was keeping friction losses as low as possible and making everything run smoothly, so we paid extra attention there.

6. Cost Estimation

We listed out every single part, whether we bought it or built it ourselves, just to get a clear cost breakdown and plan our resources better.

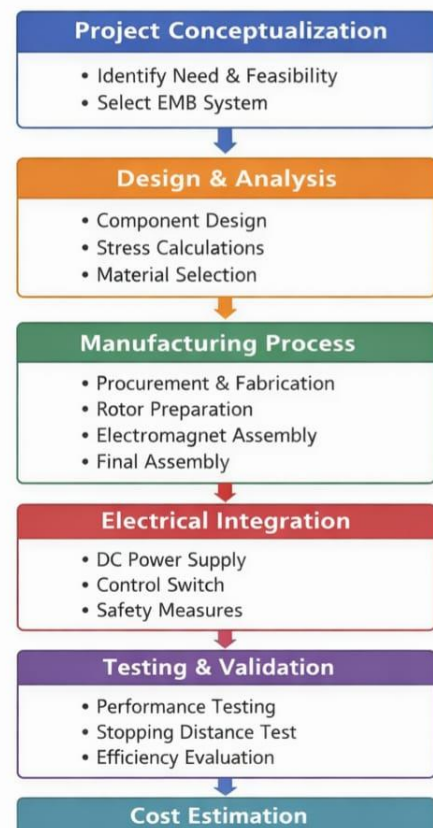

Fig-1: Flow Chart of Methodology of EMB

5. COMPONENTS OF THE SYSTEM

The major components used in the Electromagnetic braking System Include:

1. Electric Motor: Provides the rotational input power to drive the system.
2. Belt Drive: Transfers motion from the motor to the large wheel. Ensure smooth transmission of torque.
3. Large Wheel / Brake Disc: The rotating element connected to the belt. Acts as the surface where braking force is applied.

4. Supporting Frame / Base Structure: Holds the motor, wheel, and actuator in alignment. Provides stability and rigidity to the system.

5. Bearings and Mounts: Allow smooth rotation of the wheel. Reduce friction and support mechanical load.

6. Electromagnet: Generates the magnetic field required for braking.

7. Rim: Provides structural support and connection to the wheel.

The Shaft is subjected to both Twisting Moment and Bending Moment, Therefore, Torque equivalent (T_e) needs to be calculated,

$$T = \pi/16 \times \tau \times d^3, M = \pi/32 \times \sigma_b \times d^3 \text{ and}$$

$T_e = \sqrt{[T^2 + M^2]}$ While Designing a Shaft, there are two important theories,

i.e. Maximum Shear Stress Theory and Maximum Normal Stress Theory, So, According to Maximum Shear Stress Theory, Equivalent Twisting Moment,

$$T_e = \pi/16 \times \tau_{max} \times d^3$$

And, According to Maximum Normal Stress Theory, Equivalent Bending Moment,

$$M_e = \pi/32 \times \sigma_b_{max} \times d^3$$

Since, the material of shaft is ductile, we'll apply Maximum Shear Stress Theory.

Bending Moment (M) = $W \times L$ $M = 60 \times 10^3$ N.mm.

$$T_e = \sqrt{[(10.5)^2 + (60)^2]} \quad T_e = 60.91 \text{ N.m}$$

From the above Maximum Shear Stress Theory, Diameter of Shaft = 17.29 mm.

For Bearing Calculations, there is no Axial force/ Thrust on these bearings. Hence, Axial force/Thrust = 0.

There are two bearings A & B, so by support reactions, we've calculated the radial forces on each bearing.

Hence, Radial force on bearing A = 600 N And, Radial force on bearing B = 300 N

Calculating Dynamic load capacity, but for that we need Equivalent Dynamic Load, So, Equivalent Dynamic Load (P) formula, $P = X.F_r + Y.F_a$ { X = Radial load factor & Y = Axial load factor}

Dynamic load on Bearing A = 600 N Dynamic load on Bearing B = 300 N Now, Calculating Dynamic load capacity (C), $C = P (L_{10})^{(1/3)}$

Table-1: Component Of EMB

Part No.	Component	Function/Description	Source
1	Electric Motor	Provides rotational input power	Purchased
2	Belt Drive	Transfers motion from motor to wheel/disc	Purchased
3	Large Wheel / Brake Disc	Rotating element, braking surface	Purchased
4	Supporting Frame / Base Structure	Holds motor, wheel, and actuator in alignment	Manufactured
5	Bearings and Mounts	Allow smooth rotation, reduce friction	Purchased
6	Electromagnet	Generates magnetic field for braking	Manufactured (coil winding + core)
7	Rim	Provides structural support and connection to wheel	Purchased
8	Nut Bolt	To connect the Frame	Purchased

6. Calculations:

Let's consider the weight of the model = 30 kg. Therefore, $30 \times 9.81 = 294.3$ N. (300 N Approx.)

There are two different circular plates in this model, so, Force on each = $300/2 = 150$ N.

Now, Torque = $F \times R = 150 \times (140/2) = 10.5$ N.m.

Calculating Torque on Each Link, No. of links = 3,

Therefore, $10.5/3 = 3.5$ N.m

The Pitch Circle Diameter = 100 mm So, Tangential force $10.5/0.05 = 70$ N.

7. DESIGN OF THE PROJECT

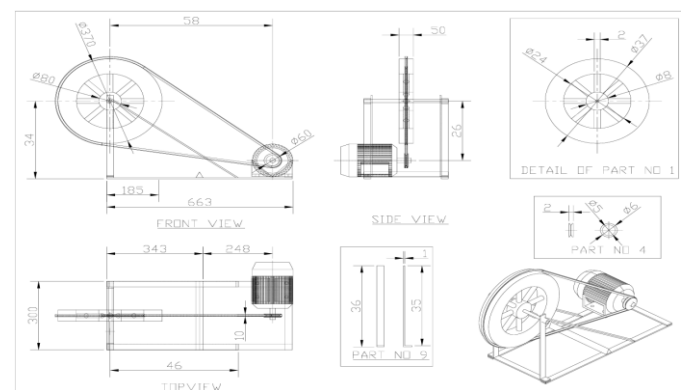

Fig-2: 2D Design Of the EMB

This figure makes the belt-driven electromagnetic braking system easy to understand. It's got everything—front, side, top, and a sharp isometric view. There are close-ups for each part, too. You see the motor, pulleys, shafts, and every support, all mounted on a solid metal frame.

The drawing's got the real essentials—like pulley diameters, shaft sizes, and the exact spacing between parts. So, no guesswork when you start building. Every part is numbered, and the close-ups highlight important details, like hole sizes, thicknesses, and lengths. There's even a Bill of Materials, so you know exactly what you need to make it all happen.

You get the full mechanical setup in one place, so you see how it all fits before anything goes together. Follow the drawing and you won't miss a step or end up scratching your head. It's straightforward—nothing extra, just what you need.

8. ADVANTAGES AND APPLICATIONS

Advantages

1. Low maintenance – Minimal mechanical parts in contact, leading to longer service life.
2. Smooth and controlled braking – Braking force can be varied by adjusting current supply.
3. Quick response time – Electromagnetic actuation provides instant braking action.
4. Energy-efficient – Converts kinetic energy into heat without excessive mechanical losses.
5. Safety enhancement – Reliable braking even at high speeds, improving overall system safety.
6. Compact design – Can be integrated easily into modern mechanical and automotive systems.

Applications

1. Railways – Widely used for safe and efficient braking in locomotives.
2. Automobiles – Applied in modern vehicles for auxiliary or emergency braking systems.
3. Industrial Machinery – Used in machines requiring precise stopping and speed control.
4. Elevators and Escalators – Ensures smooth and safe operation by preventing sudden stops.
5. Robotics and Automation Systems – Provides controlled motion and positioning.
6. Wind Turbines – Helps in controlling rotational speed and protecting equipment during high winds.
7. Cranes and Hoists – Ensures safe handling of heavy loads by providing reliable braking.

9. RESULT

Testing showed that measuring rotor stopping distance in real time led to a big drop in how far vehicles need to stop. That means less friction loss, which is exactly what you want. The EMB systems made braking quieter and smoother, beating traditional friction brakes for both comfort and dependability. Less mechanical wear means these systems

last longer and needs less upkeep. When paired with regenerative braking, EMBs actually help recover energy — a win for anyone aiming for greener electric vehicles. And they're not just for cars; the data suggests EMBs work well in railways, elevators, and heavy equipment, all places where reliability and efficiency really matter.

10. CONCLUSION

Electromagnetic braking systems really shake things up for modern cars. Instead of old-school mechanical parts grinding together, EMB uses electromagnetic force—so you get less friction, smoother stops, and not nearly as much wear on the brakes. Both research and what folks have seen on the road back this up: EMB means safer, quicker stops compared to traditional braking. Plus, it plugs right into advanced driver assistance systems and pairs nicely with regenerative braking, which makes it an obvious fit for electric and high-tech cars.

Of course, it's not perfect. EMB doesn't perform as well at low speeds and needs a stable power supply to work right. But if engineers keep improving hybrid designs and smarter control systems, those drawbacks get easier to handle. So, honestly, EMB is on track to make car braking smarter, greener, and much more dependable.

REFERENCES

- [1] K. Singh, *Automobile Engineering and Technology*, Vol. 1. New Delhi: Standard Publishers, 2010.
- [2] R.S. Khurmi and J.K. Gupta, *Machine Design*. New Delhi: S. Chand Publication, 2005.
- [3] V.B. Bhandari, *Design of Machine Elements*. New Delhi: Tata McGraw Hill, 2012.
- [4] M.A. Heald, "Magnetic Braking: Improved Theory," *American Journal of Physics*, vol. 56, no. 6, pp. 521–522, 1988.
- [5] S. Patel, "Development of the Electro-Magnetic Brake," *IJRST*, vol. 1, no. 12, May 2015.
- [6] P. Sevel, N. Kannan, and M. Mukesh, "Innovative Electro Magnetic Braking System," *IJRSET*, Apr. 2014.
- [7] A.K.S. Puttewar, N.U. Kakde, H.A. Fidvi, and B. Nandeshwar, "Enhancement of braking system in automobile using Electromagnetic Braking," *IOSR-JMCE*.
- [8] Society of Automotive Engineers, *Brake Technology, ABS/TCS, and Controlled Suspensions*. SAE World Congress, 2001.

[9]S. Wagh, A. Mahakode, A. Mehta, and V. Pyla, "Electromagnetic Braking System in Automobile," IJTRD, vol. 4, no. 3, pp. 228–231, 2017.

[10]"Eddy current brakes," Explain That Stuff. [Online]. Available: <https://www.explainthatstuff.com/eddy-current-brakes.html>

[11] "Eddy current brake," Wikipedia. [Online]. Available: https://en.wikipedia.org/wiki/Eddy_current_brake

[12] "What is a magnetic brake?" Wise Geek. [Online]. Available: <http://www.wisegeek.com/what-is-a-magnetic-brake.htm>

[13]"The design of eddy current magnet brakes," ResearchGate. [Online]. Available: https://www.researchgate.net/publication/266246472_The_design_of_eddycurrent_magnet_brakes

[14]"Electromagnetic brake," The Full Wiki. [Online]. Available: http://www.thefullwiki.org/Electromagnetic_brake

[15] International Journal of Innovative Research in Science, Engineering and Technology (IJIRSET), "Proceedings of Innovative Electro Magnetic Braking System," Vol. 3, Issue 4, Apr. 2014. [Online]. Available: <https://www.ijirset.com> make a reference according to this literature review)

BIOGRAPHIES OF AUTHORS



Siddhant Dipak Gaikwad



Vedant Tanaji Ghadge



Chinmay Sambhaji Kadam



Soham Bajarang Kadam



Mr P. V. ZORE