

Anti Sleep Alarm Project

REEYA BHANDARI¹, SANJANA DAWRE², SNEHA SHEWALE³, SAMRUDDHI WALIMBE⁴, PROF. RADHIKA NANDA⁵

^{1,2,3,4} UG Student, Dept. of Computer Engineering, Bharat College Of Engineering (Affiliation of Mumbai University), Badlapur, Maharashtra, India

⁵ HOD, Dept. of Computer Engineering, Bharat College Of Engineering (Affiliation of Mumbai University), Badlapur, Maharashtra, India

Abstract - Driver fatigue is a major cause of car accidents, especially when driving long distances or at night. This paper suggests an anti-sleep alarm system that uses an infrared sensor to keep an eye on how often people blink to find out when they are tired. The sensor keeps track of when the eyes close and sends the information to a microcontroller for analysis. The system sees that the eye is drowsy if it stays closed for longer than a certain amount of time. A buzzer and LED lights quickly make an alert to get the driver's attention again. The system is meant to be easy to use, portable, and cheap for real-time use. Tests in the lab show that it can quickly and accurately detect drowsiness. This method can help make driving safer and lower the number of accidents.

Keywords: Fatigue Detection, Eye Blink Monitoring, Infrared Sensor, Microcontroller, Alert System, Road Safety, Embedded System

1. INTRODUCTION

Road safety remains a critical global concern, with driver fatigue being one of the major causes of traffic accidents [1]. Reduced alertness due to tiredness slows reaction time, decreases concentration, and affects decision-making ability, significantly increasing the risk of collisions [2]. Factors such as long driving hours, night travel, and insufficient rest further worsen this condition, making fatigue detection an important research area for improving transportation safety [3].

In recent years, various approaches have been developed to identify drowsiness in drivers. Vision-based techniques analyze facial features such as eye closure, blink rate, and head movement to evaluate alertness levels [4]. Other methods involve wearable devices that monitor physiological signals like heart rate and brain activity to detect fatigue [5]. These techniques have contributed significantly to driver safety, but many systems are complex or expensive, limiting their practical usage.

This paper presents the design and development of an Anti-Sleep Alarm System that detects early signs of driver drowsiness and provides immediate alerts [6]. The proposed system uses an infrared eye blink sensor to monitor eye activity and a microcontroller to process the data [7]. When prolonged eye closure is detected, the system triggers an alert using a buzzer and LED indicators to regain the driver's attention [8].

Research Objectives

- To develop an effective solution to reduce accidents caused by driver drowsiness [9]
- To design a portable or wearable anti-sleep detection system using eye blink sensing technology [10]
- To evaluate system performance through real-time testing and analysis [11]
- To study user comfort, reliability, and adaptability of the proposed system [12]

2. LITERATURE SURVEY

Driver drowsiness detection has been widely studied due to its strong impact on road safety. Research shows that fatigue-related accidents account for a significant portion of road incidents, highlighting the need for effective detection systems [1]. Existing studies classify drowsiness detection techniques into three main categories: behavioral, physiological, and vehicle-based approaches [2]. Behavioral-based methods are among the most commonly used techniques, as they monitor visible signs such as eye blinking, eye closure, yawning, and head movement [3]. Eye blink detection, in particular, has

proven to be a reliable indicator of fatigue, with high detection accuracy when appropriate thresholds are applied [4]. Many systems use camera-based image processing to track these features, although their performance can be affected by lighting conditions and head orientation.

Physiological approaches involve monitoring biological signals such as electroencephalogram (EEG), electrocardiogram (ECG), and electrooculogram (EoG) to detect early signs of fatigue [5]. These methods provide high accuracy since body signals change before visible symptoms appear. However, they require wearable sensors, making them less practical for everyday use due to discomfort and higher cost. Vehicle-based techniques analyze driving patterns such as steering movement, lane deviation, and vehicle speed to identify abnormal behavior [6]. While these systems are non-intrusive, they often detect drowsiness only after driving performance has already been affected, which may be too late to prevent accidents.

Recent research has focused on developing simple and cost-effective solutions using embedded systems and sensors. Eye

3. COMPONENTS AND MODULES

The development of an anti-sleep alarm system for drivers involves the integration of both hardware and software elements to achieve continuous monitoring and timely alert generation. The hardware section mainly consists of sensing devices, control units, and alert components that work together to detect drowsiness. On the other hand, the software part includes programming platforms and interfacing techniques required for data processing and system control.

3.1 HARDWARE REQUIREMENTS

1. Infrared (IR) Sensor Module

The infrared sensor module is used to detect eye blink activity by sensing the reflection of IR rays from the eye. It continuously monitors whether the eye is open or closed. When the eye remains closed for a longer duration, it indicates possible drowsiness. The sensor converts this activity into electrical signals. These signals are then sent to the microcontroller for further processing.

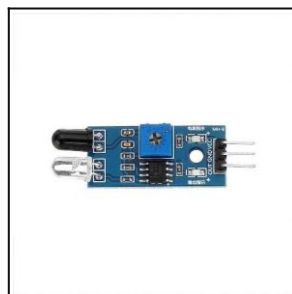

Fig-1: IR SENSOR

2. 5V Dual Channel Relay Module

The dual channel relay module is used to control multiple output devices simultaneously. It allows switching of two independent circuits using a single control unit. This module is useful for activating components like motors and alarms together. It operates using low voltage signals from the microcontroller. It also provides electrical isolation between control and output circuits.

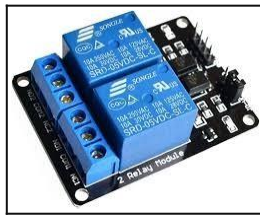

Fig-2: 5V Dual Channel Relay Module

3. 5V Relay Module

The 5V relay module acts as an electrically operated switch. It is used to control high-power devices using low-power signals. When triggered, it opens or closes the circuit connected to the load. This ensures safe operation of external components. It is commonly used in automation and control systems.



Fig-3 : 5V Relay Module

4. Relay Pin Configuration

Relay pin configuration defines how the relay is connected within the circuit. It includes pins such as Normally Open (NO), Normally Closed (NC), and Common (COM). These pins determine how current flows in different states. Proper pin configuration ensures correct functioning of connected devices. It is essential for reliable switching operations.

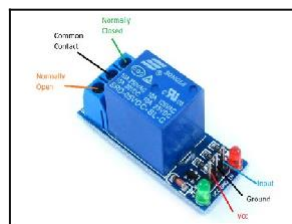

Fig-4 : Relay Pin Configuration

5. 25V / 1000µF Capacitor

The capacitor is used for filtering and stabilizing voltage in the circuit. It helps in reducing noise and sudden voltage fluctuations. This ensures smooth operation of electronic components. The high capacitance allows it to store and release energy when needed. It improves the overall efficiency and reliability of the system.



Fig-5 :25V / 1000µF Capacitor

6. LED Bulb

7.

The LED bulb is used as a visual indicator in the system.

It glows when drowsiness is detected. This provides an immediate visual alert to the user. LEDs consume very low power and have a long lifespan. They are commonly used in embedded systems for indication purposes.



Fig-6 :Led Bulb

8. Resistor

The resistor is used to control the flow of current in the circuit. It protects components like LEDs from excessive current. By limiting current, it ensures safe operation of the system. Different resistance values are used depending on circuit requirements. It is a basic but essential component in electronic circuits.

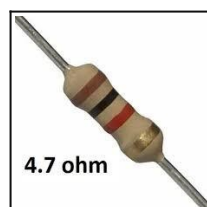

Fig-7 :Resistor

9. Sound Buzzer / Alarm

The buzzer is used to generate an audible alert when drowsiness is detected. It helps in immediately grabbing the attention of the driver. The sound continues until the driver responds. It is simple, compact, and easy to interface with microcontrollers. This makes it highly effective for alert systems.

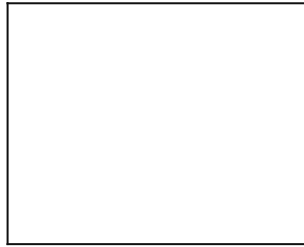

Fig-8 : Sound Buzzer

10. 60 RPM Gear Motor

The gear motor is used to simulate mechanical action in the system. It operates at a fixed speed of 60 revolutions per minute. This motor can represent actions like vehicle control or movement. It provides high torque at low speed. It is suitable for controlled and steady operations.

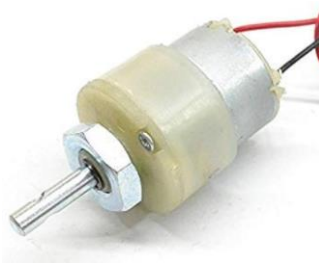

Fig-9 : 60 RPM Gear Motor

11. DC Motor (Variable Speed Motor)

The DC motor is used to demonstrate motion control based on system output. Its speed can vary depending on input voltage or control signals. It helps in simulating real-world applications like vehicle response. The motor can be controlled using relay modules. It is widely used in automation and embedded systems.



Fig-10: DC-Motor

3.2 SOFTWARE REQUIREMENTS

1. Arduino IDE:

The Arduino Integrated Development Environment (IDE) is a user-friendly software platform used for writing, editing, and uploading code to Arduino boards. It provides features such as a code editor, output console, toolbar options, and menu navigation for efficient program development. The IDE allows seamless communication between the computer and the Arduino hardware, enabling easy program execution.

Programs written in the Arduino IDE are called sketches and are created using the built-in text editor. These sketches are saved with a “.ino” file extension. The IDE organizes all projects within a sketchbook, which acts as a central directory for storing and managing files. Users can open and manage their projects through the Sketchbook menu or toolbar options. By default, a sketchbook folder is automatically created during installation, and its location can be changed through the settings or preferences menu.

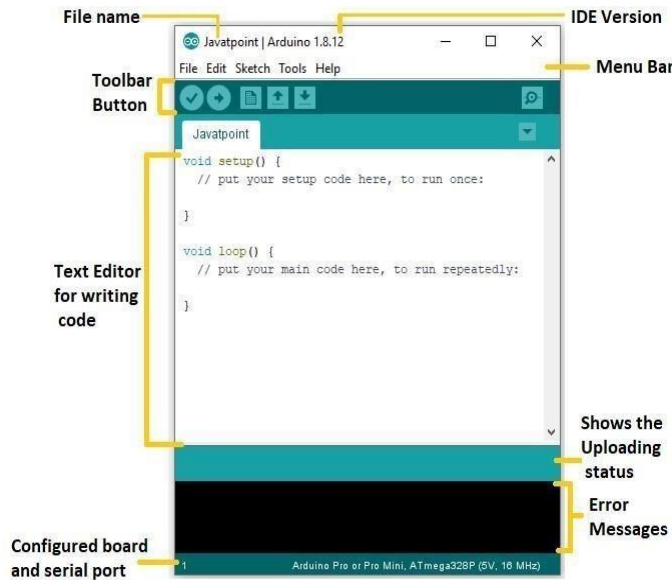

Fig-1: Arduino IDE Environment

4 .METHODOLOGY AND FLOW DIAGRAM

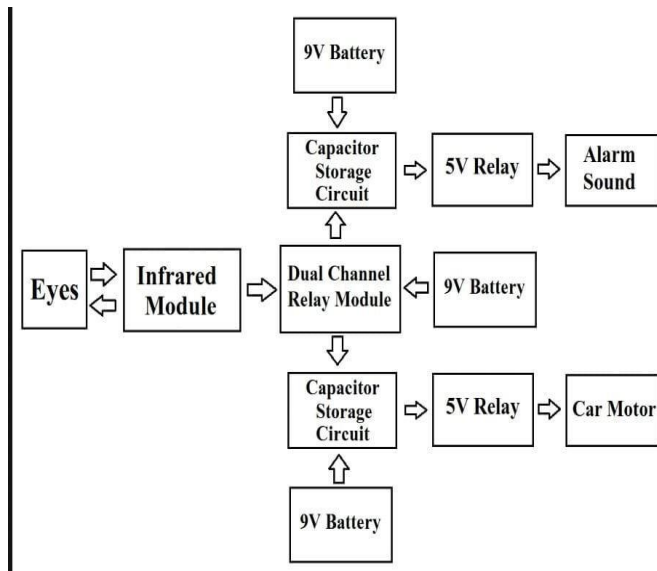

Fig-1: Methodology

The working of the proposed Anti-Sleep Alarm System begins with the detection of eye activity using an infrared (IR) module. The IR sensor is positioned in such a way that it continuously monitors the driver’s eyes. It detects whether the eyes are open or closed based on the reflection of infrared rays and sends the signal to the dual

channel relay module.

The dual channel relay module acts as the central control unit of the system. It processes the input received from the IR sensor and determines whether the driver is alert or drowsy. When the eye remains closed beyond a certain threshold, the system identifies it as a fatigue condition and activates the output section.

The system uses capacitor storage circuits powered by 9V batteries to ensure stable voltage supply and smooth operation of the components. One relay path is connected to the alarm system, where a 5V relay triggers the buzzer to generate an audible alert. This warning helps in immediately grabbing the driver's attention.

Simultaneously, another relay path controls the motor section. A 5V relay activates the car motor (or gear motor), which represents a mechanical response such as slowing down or controlling vehicle movement. This dual-action mechanism enhances safety by combining alert generation with system response. Overall, the system operates continuously in real time, ensuring quick detection and immediate action. The integration of sensors, relays, and power management components makes the system reliable, efficient, and suitable for practical implementation in reducing drowsiness-related accidents.

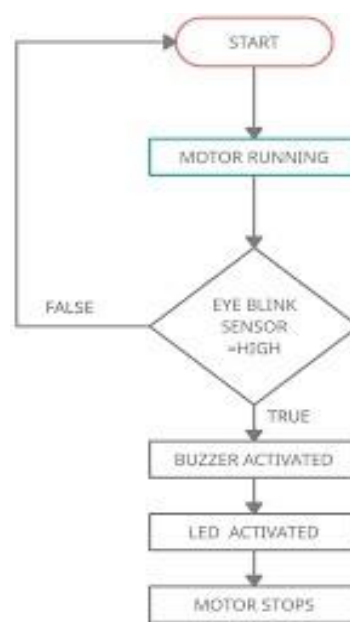

Fig-2: Flow Diagram

The process starts with the system being powered on and the motor running. The IR eye blink sensor continuously monitors the eye condition. If the sensor detects a normal state (eyes open), the system keeps running. If the sensor detects eye closure (drowsiness), the buzzer is activated to alert the driver. At the same time, the LED is turned on as a visual warning. Finally, the motor stops to simulate vehicle safety action.

5 . RESULTS & ANALYSIS

The developed Anti-Sleep Alarm System was successfully implemented and tested using the designed circuit and hardware prototype. The system effectively monitored eye blink activity using the IR sensor mounted on goggles. During testing, when the eyes remained open, the system maintained normal operation with the motor running continuously.

When the eyes were intentionally closed for a longer duration, the IR sensor detected the condition accurately and sent a signal to the relay module. As a result, the buzzer was activated immediately, and the LED indicator turned on, providing both audible and visual alerts. At the same time, the motor stopped functioning, simulating a safety response similar to vehicle control.

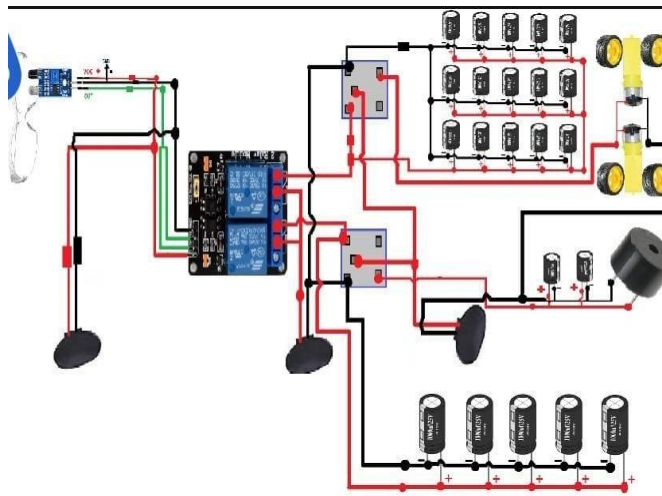

Fig-1: Circuit Diagram

The circuit diagram represents the connection between the sensing unit, control unit, and output components of the anti-sleep alarm system. The IR sensor is used as the input device, which detects eye closure and sends signals to the relay module. The dual channel relay module acts as the main control unit, directing signals to different output paths based on the sensor input.

The power supply is provided using 9V batteries, and capacitor storage circuits are included to stabilize voltage and reduce noise. One relay channel is connected to the buzzer and LED, forming the alert system. When drowsiness is detected, this relay activates the alarm to notify the user.

The second relay channel is connected to the motor section. When triggered, it controls the DC motor or gear motor, simulating a vehicle response such as stopping or slowing down. The use of relays ensures safe power output devices.

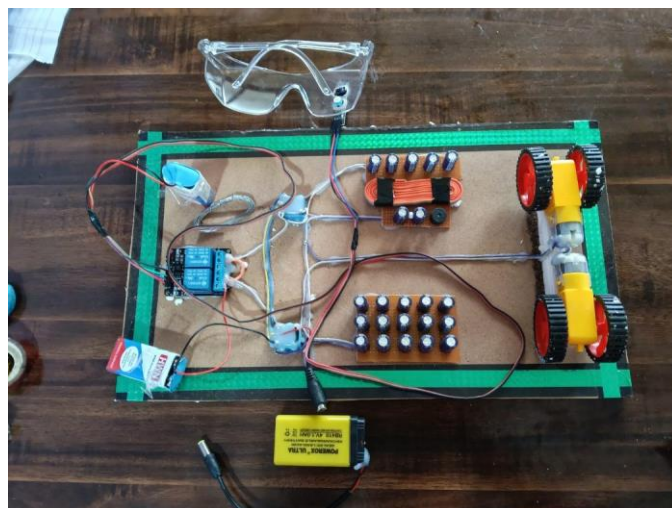

Fig-2 : Final result

From the experimental results, it can be concluded that the system is capable of detecting drowsiness efficiently and triggering appropriate safety actions. The design proves to be cost-effective, simple, and suitable for real-time applications. However, performance may vary under different environmental conditions such as lighting and sensor positioning, which can be further improved in future enhancements.

6. CONCLUSION

This project presents a practical Anti-Sleep Alarm System designed to address the problem of driver fatigue. The system effectively detects drowsiness by analyzing eye blink patterns using an IR sensor and processes the data through a control unit. Upon detecting prolonged eye closure, it activates an alert mechanism, including a buzzer and LED, to warn the user instantly.

In addition, the use of relay modules to control the motor demonstrates a safety response mechanism, which can be extended to real vehicle applications. The system is simple in design, economical, and easy to operate, making it suitable for real-time implementation.

The results indicate that the proposed system performs reliably under test conditions and can help in reducing accidents caused by driver inattention. Future improvements can focus on increasing accuracy and incorporating advanced features for enhanced performance.

7. FUTURE ENHANCEMENT

The proposed Anti-Sleep Alarm System can be further improved by integrating advanced technologies to enhance accuracy and functionality. One possible enhancement is the incorporation of camera-based vision systems for more precise detection of facial features such as eye movement, yawning, and head position. Additionally, machine learning algorithms can be implemented to analyze driver behavior patterns and provide adaptive, personalized fatigue detection.

The system can also be upgraded using IoT technology to enable real-time data transmission and remote monitoring through cloud platforms. Integration with vehicle control systems can allow automatic actions such as speed reduction or engine control in critical situations. Furthermore, the use of wearable and more compact sensors can improve user comfort and usability.

Future developments may also focus on improving system reliability under varying environmental conditions such as lighting and noise. By combining multiple sensing techniques, the overall performance and robustness of the system can be significantly enhanced.

8. REFERENCE

- [1] J. S. Bajaj, R. Singh, and A. Kumar, "System and Method for Driver Drowsiness Detection Using Behavioral and Sensor-Based Physiological Measures," *Sensors*, vol. 23, no. 3, pp. 1–18, 2023.
- [2] Y. Albadawi, M. Takruri, and M. Awad, "A Review of Recent Developments in Driver Drowsiness Detection Systems," *Sensors*, vol. 22, no. 5, pp. 1–25, 2022.
- [3] O. F. Hassan, M. Elhoseny, and S. Abdelaziz, "Real-Time Driver Drowsiness Detection Using Deep Learning Techniques," *Scientific Reports*, vol. 15, pp. 1–12, 2025.
- [4] A. A. Saleem, M. Al-Ayyoub, and Y. Jararweh, "A Systematic Review of Physiological Signal-Based Driver Drowsiness Detection Systems," *Cognitive Neurodynamics*, vol. 17, pp. 1–20, 2023.
- [5] K. Avinash Babu and G. Eswara Rao, "Driver Drowsiness Detection System for Accident Prevention," *International Research Journal on Advanced Engineering Hub*, vol. 6, no. 2, pp. 45–50, 2024.
- [6] F. Liu, X. Zhang, and Y. Wang, "Driver Fatigue Detection Based on Deep Learning: A Review," *Engineering Applications of Artificial Intelligence*, vol. 114, pp. 1–15, 2022.
- [7] H. Verma, S. Patel, and R. Shah, "Driver Drowsiness Detection Using Embedded Systems," *Journal of Data Acquisition and Processing*, vol. 38, no. 3, pp. 210–218, 2023.

- [8] Y. Yashwanth and J. S. Singh, "Driver's Drowsiness Detection Using Eye and Facial Features," in IEEE Region 10 Conference (TENCON), pp. 1622–1625, 2019.
- [9] U. M. Kumar, D. Singh, and S. Jugran, "A System on Intelligent Driver Drowsiness Detection Method," International Journal of Engineering and Technology, vol. 7, no. 3, pp. 160–162, 2018.
- [10] H. U. R. Siddiqui et al., "Non-Invasive Driver Drowsiness Detection System," Sensors, vol. 21, no. 14, pp. 1–20, 2021.