

# IOT Based Vehicle Accident Detection and Tracking System Using GPS Modem

Srushti P. Bochare<sup>1</sup>, Ashvini G. Feran<sup>2</sup>, Shraddha S. Naswale<sup>3</sup>, Pallavi S. Satao<sup>4</sup>,  
Mrs. Nanda Y. Mhaisagar<sup>5</sup>

<sup>1</sup>Student of Electronics and Telecommunication, Mauli College of Engineering and Technology, Shegaon-444203(Maharashtra)India

<sup>2</sup>Student of Electronics and Telecommunication, Mauli College of Engineering and Technology, Shegaon-444203(Maharashtra)India

<sup>3</sup>Student of Electronics and Telecommunication, Mauli College of Engineering and Technology, Shegaon-444203(Maharashtra)India

<sup>4</sup>Student of Electronics and Telecommunication, Mauli College of Engineering and Technology, Shegaon-444203(Maharashtra)India

<sup>5</sup>Assistant Professor at Electronic and Telecommunication, Mauli College of Engineering and Technology, Shegaon-444203(Maharashtra) India

\*\*\*

**Abstract** – This research presents an innovative approach to enhance road safety with the development of an Internet of Things (IoT)-based Vehicle Accident Detection and Live Tracking System. The system utilizes the ESP32 microcontroller, Firebase cloud platform, tilt sensor, and a 3-axis sensor for real-time detection and response to vehicular accidents. The ESP32 microcontroller acts as the central processing unit, seamlessly integrating with both the tilt sensor and the 3-axis sensor. The tilt sensor detects sudden changes in the vehicle's orientation, indicating a potential accident, while the 3-axis sensor captures acceleration and deceleration data for precise accident detection. When a potential accident is detected, the system initiates immediate live tracking through the Firebase cloud platform. Firebase enables real-time communication between the vehicle and a designated monitoring center, facilitating swift emergency response measures. Utilizing Firebase's robust features ensures the security and integrity of sensitive information. The live tracking feature enables authorities to monitor the vehicle's location and condition in real-time, enabling prompt intervention and assistance, thereby reducing emergency response times and improving road safety. Implementation of this IoT-based system has the potential to revolutionize accident detection and response mechanisms, creating a safer transportation environment. The combination of ESP32, Firebase, tilt sensor, and 3-axis sensor technologies offers a robust and scalable solution for mitigating the impact of vehicular accidents on both lives and property.

**Key Words:** 16X2 lcd display, 3axis accelerometer sensor, vibration sensor, GPS module, Motor driver module, motor, speed sensor, ESP32

## 1. INTRODUCTION

The Internet of Things (IoT) has emerged as a transformative technology, revolutionizing the way we connect and interact with the world around us. By interconnecting embedded computing devices within the existing internet infrastructure, IoT offers unparalleled levels of connectivity, enabling seamless communication between devices, systems, and services. This connectivity extends far beyond traditional machine-to-machine (M2M) communications, encompassing a diverse range of protocols, domains, and applications. In virtually every field of automation, IoT has paved the way for innovative solutions and advanced applications, unlocking new possibilities for efficiency, productivity, and convenience. From optimizing energy distribution through Smart Grids to revolutionizing healthcare with heart monitoring implants, IoT has become an integral part of modern life. One particularly promising application of IoT technology lies in the realm of vehicle safety. With the proliferation of smart objects and embedded sensors, it is now possible to develop sophisticated systems for accident detection and tracking. Our project, "IoT BASED VEHICLE ACCIDENT DETECTION AND TRACKING SYSTEM USING GPS MODEM," represents a pioneering effort in this domain, leveraging IoT principles to enhance road safety and emergency response capabilities. At the heart of our system is the NODE MCU, serving as the central hub for communication and coordination. When activated, the **system** provides a visual indication of power supply through an LED indicator, signalling its readiness to Vibration sensors play a crucial role in accident detection, promptly sensing obstacles or collisions and triggering interrupts to the Raspberry Pi. This real-time data is then processed and analysed, facilitating swift and accurate decision-making in response to emergencies. Meanwhile, the GPS modem enables precise location tracking, allowing

us to pinpoint the exact coordinates of vehicles involved in accidents. This information is seamlessly relayed to a dedicated mobile application via the internet, providing users with vital insights into the location and severity of incidents. By harnessing the power of IoT technology, our system not only detects accidents but also empowers stakeholders with actionable data for effective response and mitigation efforts. Through modulation and demodulation, the modem ensures reliable communication, enabling seamless transmission of critical information in real-time. As we delve deeper into the details of our project, we aim to shed light on the transformative potential of IoT in enhancing vehicle safety and revolutionizing emergency response systems. With a focus on innovation and efficiency, we strive to contribute to a safer, more connected future for all.

### 1.1 Block Diagram

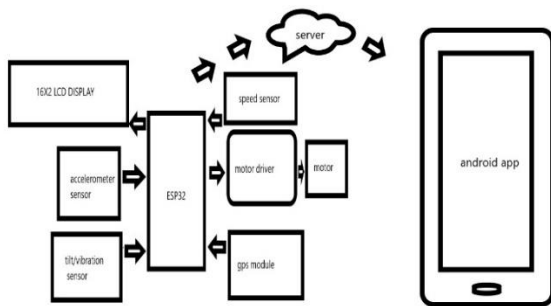

Fig1.1 : Block Diagram

At the center of the block diagram is the ESP32 microcontroller, which serves as the brain of the system. The ESP32 is connected to several different sensors and modules, including the LCD display, GPS module, accelerometer sensor, tilt vibration sensor, speed sensor, and motor driver, as well as a WIFI module for connecting to the internet. The LCD display is used to show sensor values in real-time, making it easy for the user to monitor the system's performance. The ESP32 communicates with the LCD display using a serial interface, sending data to be displayed on the screen. The GPS module is used to determine the system's location, providing coordinates that can be used for navigation or other purposes. The GPS module communicates with the ESP32 over a serial interface, sending data about the system's location. The accelerometer sensor is used to measure the system's acceleration and tilt, providing data that can be used to control the system's movement. The accelerometer communicates with the ESP32 using an analog interface, sending data about the system's acceleration and tilt.

The tilt vibration sensor is used to detect vibrations in the system, providing data that can be used to monitor the system's stability. The tilt vibration sensor communicates with the ESP32 using an analog interface, sending data about the system's vibrations. The speed sensor is used to

calculate the speed of the motor, providing data that can be used to control the motor's speed. The speed sensor communicates with the ESP32 using a digital interface, sending data about the motor's speed. The motor driver is used to control the motor's speed and direction, providing power to the motor when necessary. The motor driver communicates with the ESP32 using a digital interface, receiving commands to control the motor's speed and direction. The Firebase server is used to store and retrieve data from the system. The ESP32 communicates with the Firebase server using the Firebase API over Wi-Fi. The ESP32 sends sensor data to the Firebase server, where it's stored for later retrieval. An application can be developed that retrieves the data from the Firebase server and displays it to the user. Overall, this block diagram illustrates a system that's connected to an ESP32 microcontroller and includes a variety of sensors and modules that can be used to monitor and control the system's performance, as well as a Firebase server for storing and retrieving data. This system could be used for a variety of applications, such as monitoring the performance of a vehicle or machine and storing the data for analysis.

### 1.2. Circuit Diagram

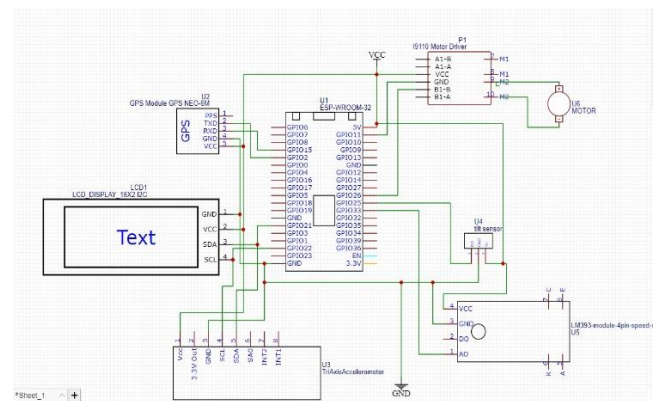

Fig1.2. Circuit Diagram

The ESP32 is at the center of the system and is connected to various sensor that perform different functions. The first is the LCD display, which shows the sensor values in real- time. The display is connected to the ESP32 through the I2C interface. The second is the GPS module that retrieves the location of the vehicle. The GPS module is connected to the ESP32 through the serial interface. The third sensor includes the accelerometer sensor, tilt vibration sensor, and speed sensor. These sensors detect any sudden changes in speed, direction, or tilting of the vehicle. The accelerometer sensor and tilt vibration sensor are connected to the ESP32 through the ADC interface, while the speed sensor is connected to the ESP32 through the GPIO interface. The fourth includes the motor driver that controls the motor. The motor driver is connected to the ESP32 through the PWM interface. The ESP32 sends a

signal to the motor driver, which controls the motor speed. Finally, all the sensor data is sent to the Firebase server. The ESP32 is connected to the Firebase server through the Wi-Fi interface. The ESP32 sends the sensor data to the Firebase server using the Firebase API. In summary, the IoT based accident detection system connected to an ESP32 includes an LCD display, GPS module, accelerometer sensor, tilt vibration sensor, speed sensor, motor driver, and Firebase server. The ESP32 retrieves data from each block and sends it to the Firebase server, where it can be viewed in real-time.

### 1.3 Software requirement

#### 1.3.1 Arduino Software Tools

Another integral part of the Arduino ecosystem are its software tools. The Arduino Integrated Development Environment (IDE) serves as a comprehensive platform for programming Arduino boards. Essentially, it's a software tool that streamlines the entire process of developing and uploading code to your Arduino microcontroller. Before the IDE, programming microcontrollers required significant expertise in both electronics and computer science. However, with the Arduino IDE, this process has become much more accessible to beginners and enthusiasts alike. From writing the code to compiling it into machine language and finally uploading it onto the board, the IDE handles every step seamlessly. This user-friendly interface has democratized microcontroller programming, making it accessible to a wider audience. Today, there are multiple versions of the Arduino IDE available, catering to different user preferences and needs.

- Arduino IDE 1.8.x (classic)
- Arduino IDE 2 (new)
- Arduino Web Editor (online)

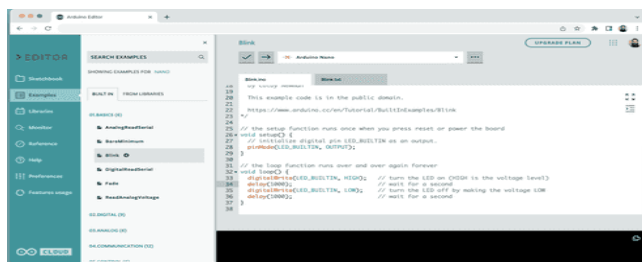

Fig 1.3: Web Editor

## 2. Methodology

**1. Requirement Analysis:** Conduct a thorough analysis to understand the specific safety needs and preferences of the target users. This involves gathering insights through surveys, interviews, and consultations with potential users and stakeholders.

**2. Technological Selection:** Identify and select the appropriate hardware components and technologies to fulfill the system requirements. This includes choosing GPS modules for location tracking, Wi-Fi\_\_33 modules (such as ESP32) for connectivity, panic buttons for emergency triggers, and a robust backend system like Firebase Cloud for data storage and synchronization.

**3. System Architecture Design:** Develop a comprehensive system architecture that outlines the integration of chosen components. Define the communication protocols, data flow, and user interfaces to ensure a seamless and effective operation of the Women's Security System.

**4. Hardware Integration:** - Implement the selected hardware components into a cohesive system. This involves connecting and configuring GPS modules, Wi-Fi\_\_33 modules, SOS switches, and any wearable devices to create a functional prototype.

**5. Mobile Application Development:** - Design and develop a user-friendly mobile application that serves as the interface for the Women's Security System. Ensure the application allows users to monitor the live location, receive emergency alerts, and trigger assistance seamlessly.

**6. Real-Time Communication Mechanisms:** - Establish communication mechanisms between the hardware components and the mobile application to facilitate real-time data transfer. This includes setting up communication protocols for GPS data, emergency alerts, and system status updates.

## 3. RESULTS AND DISCUSSION



Fig 3.1: Accident Detection Module

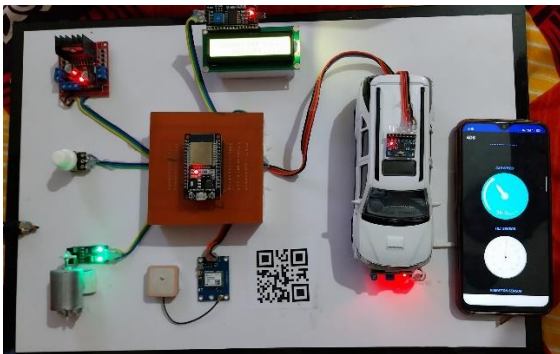

**Fig 3.2:** All Components Activate

**4. APPLICATIONS** • Real-time accident detection • Emergency response: • post-accident analysis: • Insurance claims • Vehicle tracking

## 5. CONCLUSIONS

The IoT-based vehicle accident detection and tracking system using GPS Modem presented in this project offers a promising solution to address the rising number of casualties associated with road collisions. By leveraging IoT technology, our system not only detects accidents but also alerts authorities promptly, facilitating timely rescue operations and potentially saving lives. We discussed various strategies for accident detection and prevention, including the use of sensors such as accelerometers, shock sensors, and pressure sensors, coupled with machine learning techniques such as neural networks and support vector machines. These strategies aim to enhance the accuracy and efficiency of accident detection, as well as prevent accidents through measures such as detecting drunk or drowsy drivers and regulating vehicle speed. Once an accident is detected, the system communicates the information to emergency services, enabling them to provide swift assistance. Overall, this system offers several advantages, including mitigating road collisions, pinpointing precise accident locations, and streamlining rescue operations.

## 6. REFERENCES

- [1] Aishwarya S.R, Ashish Rai, Charitha, Prasanth M.A, and Savitha S.C “An IoT based vehicle accident prevention and tracking system for night drivers” proc. IEEE, vol.3, no.4, pp.2320-9798 2015
- [2] Sadhana B Shabrin, Bhagyashree Jagadish Nikharge, Maithri M Poojary and T Pooja, “Smart helmet-intelligent safety for motorcyclist using raspberry pi and open CV”, proc.IEEE,vol.03, no.03 pp.2395-0056 2016
- [3] Jagdish A. Patel, Aringale Shubhangi, Shweta Joshi, Aarti Pawar and Namrata Bari discussed on

“Raspberry Pi based smart home”, Proc. IEEE, vol.6, no.3, pp.2321-3361 2016

- [4] Dr. pankaj Tomar and preeti Mehta focused on “ An Efficient Management System based on Face Recognition using Matlab and Raspberry Pi 2”, Proc-IEEE, vol.3, no.5, pp.239 2016
- [5] T. Anitha and T. Uppalaigh focused on “Android based home automation using Raspberry pi”, Proc-IEEE, vol.04, no.01, pp-2351-8665 2016
- [6] Shailesh Bhavthankar and Prof. H.G.Sayyed discussed on” Wireless System for Vehicle Accident Detection and Reporting using Accelerometer and GPS”, Proc .IEEE vol.6, no.8, pp-2229-5518 2015
- [7] Md.Shaad Mahmud, Honggang Wang, A.M.Esfar-EAlam and Hua Fang has focused on “A Wireless Health Monitoring System Using Mobile Phone Accessories”, ProcIEEE,vol.1, no.99, pp-2327-4662 2016
- [8] Sarika R. Gujar and Prof. A. R. Itkikar has focused on “Advanced Embedded System of Vehicle Accident Detection and Tracking System”, Proc-IEEE, vol.5, no.2, pp- 2277 128X 2015