

Generation of Electricity by Hybrid Mode of- Vertical Axis Wind Turbine With Solar Panel

Mr Sushant Singh¹, Mr Rushikesh Dolas², Mr Ashish Kumar³, Mr. Chetan Sawale⁴,
Mr. Tejas Mahakal⁵, Mr. Prof. A.V. Dumbre⁶

^{1,2,3,4,5} Department of Mechanical Engineering, PDEA College Of Engineering Pune, India.

⁶ Assistant Professor of Department of Mechanical Engineering PDEA College Of Engineering Pune, India.

Abstract

The globe is dealing with several issues like energy security, climate change, and economic sustainability. Though conventional energy sources are worldwide for the generation of energy, they have certain limitations like limited storage and pollution problems, Transportation issues so nowadays the world is looking for alternatives to conventional fuels. Renewable Energy sources are eco-friendly, and they are easily & abundantly available in nature. Solar and wind power are two examples of renewable energy sources that have been cited as important answers to these problems. It is challenging to produce a dependable and consistent power supply since these energy sources are unstable and irregular. Hybrid energy systems that mix solar and wind power have become an appealing answer to this problem. The design, functionality, and possible advantages of hybrid solar-wind energy systems are all covered in detail in this study.

Keywords: - Hybrid, Solar, Wind, Renewable, Windmill, Turbine, etc.

Introduction

The globe is now experiencing a developing energy crisis as a result of the world's rising energy needs and the exhaustion of conventional energy sources like oil, gas, and coal. An increasing interest in sustainable, eco-friendly, and economical renewable energy sources is the result of this. The potential for generating electricity from solar and wind energy makes them two of the most attractive renewable energy sources. Each source does, however, have some drawbacks that a hybrid system may get around. The need for renewable energy sources has become increasingly urgent in recent years due to the effects of climate change. Global temperatures have been steadily rising, leading to more frequent and severe weather events such as hurricanes, floods, and droughts. The burning of fossil fuels for energy is one of the main contributors to greenhouse gas emissions, which are the primary cause of climate change. Therefore, it is crucial to transition to renewable energy sources that do not emit greenhouse gases and do not contribute to climate change.

A renewable energy system that produces electricity using both solar panels and wind turbines is known as a hybrid type of solar and wind power. The combination of these two sources results in a more dependable and stable power supply by overcoming the shortcomings of each source alone. The hybrid system is a potential approach to supplying contemporary society's energy needs while lowering greenhouse gas emissions.

Solar Energy

Solar energy is the most abundant renewable energy source on the planet, potentially generating an estimated 5,000 times more energy than the world's current energy consumption. Solar energy is produced by converting sunlight into electricity through the use of solar panels. The process of converting sunlight into electricity involves using photovoltaic (PV) cells, which are made of semiconductor materials capable of absorbing photons of sunlight and converting them into electrical energy.

Wind Energy

Wind energy is another promising renewable energy source, which is generated by harnessing the power of wind turbines. Wind turbines convert the kinetic energy of the wind into electrical energy, which can be used to power homes and businesses. Wind turbines consist of a rotor, which is mounted on a tall tower, and a generator, which converts the mechanical energy of the rotor into electrical energy.

Related Work

The concept of combining solar and wind power in a hybrid renewable energy system is not new, and there has been extensive research on this topic over the years. Several studies have investigated the technical and economic feasibility of hybrid systems, and have identified the potential benefits of such systems.

Literature Review

1. In a study conducted by Kumar et al. (2016), a hybrid solar-wind energy system was proposed for off-grid electrification in a rural area in India. The study found that a hybrid system could provide a more reliable source of electricity than a stand-alone solar or wind system, and could reduce the capital cost of the system
2. Another study conducted by Li et al. (2017) investigated the optimal sizing of a hybrid solar-wind system for a remote island in China. The study found that a hybrid system could reduce the cost of energy by up to 30% compared to a stand-alone solar or wind system, and could provide a more stable source of electricity
3. In a study conducted by Rizk et al. (2019), a hybrid solar-wind system was proposed for a residential building in Lebanon. The study found that a hybrid system could provide a more reliable source of electricity than a stand-alone solar or wind system, and could reduce the payback period of the system.
4. Analysing the literature review on the design and development of vertical axis wind turbine blades was done by D.A. Nikam. This essay illustrates how wind turbines, such as vertical and horizontal ones, are frequently used to produce electricity. The horizontal windmill is extensively utilised for large-scale applications that need more room and significant financial outlay. The vertical wind turbine, however, is inexpensive and suited for household use. The wind turbine's blade design and orientation have an impact on how much power is produced. Setting the appropriate parameter for the blade design will optimise this. The experimental finding suggests that the turbine's performance and energy output are significantly impacted by the blade.
5. Altab Hossain looked into the creation of a 1/3 size vertical axis wind turbine for the production of electrical power. In this study, wind energy and a belt power transmission system are used to generate electricity from a wind turbine. The wind turbine is built with a blade-to-drag device ratio of 1:3. Different wind speeds are used for the experiment, and the power generated by the windmill is determined. The testing findings show that although 709 W of power was created at a speed of 25 m/s, 567 W was produced at a speed of 20 m/s. Due to this, when the velocity is high, the power generation will increase.

OBJECTIVE

1. To evaluate the benefits and challenges of a hybrid solar-wind energy system for renewable energy production.
2. To develop a mathematical model for optimizing the design of a hybrid solar-wind energy system based on system parameters such as solar panel area, wind turbine capacity, and battery capacity.
3. To investigate the impact of system parameters on energy production and cost.
4. To compare the performance of a hybrid solar-wind energy system with standalone solar and wind energy systems in terms of energy production, reliability, and cost.
5. To provide insights into the design and optimization of hybrid solar-wind energy systems for renewable energy production that can be applied in practical settings.

PROBLEM STATEMENT

The need for sustainable and dependable renewable energy sources is the issue this research study seeks to address to lessen the environmental effect of conventional energy sources and attain energy security. Although both solar and wind energy are potential renewable energy sources, each has specific benefits and drawbacks. These restrictions can be overcome with a hybrid solar-wind energy system, which combines the two energy sources to increase system dependability and efficiency.

However, to build and optimise a hybrid solar-wind energy system, it is necessary to comprehend the system's advantages and disadvantages as well as the effects of system parameters on energy output and cost. By creating a mathematical

model to optimise the design of a hybrid solar-wind energy system for maximum energy output and minimal cost, this research article tries to address these difficulties.

METHODOLOGY

This research paper uses a mathematical model to optimize the design of the hybrid solar-wind energy system. The model is based on the energy balance equation, which considers the energy input and output of the system. The model also takes into account the system parameters such as solar panel area, wind turbine capacity, and battery capacity. The model is solved using simulation software to optimize the system design for maximum energy production and minimum cost.

Design and Operation of Hybrid Solar-Wind Systems:

Hybrid solar-wind systems can be designed in various configurations, depending on the specific application and site conditions. Generally, these systems consist of a solar array, a wind turbine, a power conditioning unit, and a battery bank. The power conditioning unit converts the DC power generated by the solar array and wind turbine into AC power, which can be used to supply the load or fed into the grid. The battery bank is used to store excess energy generated by the system, which can be used during periods of low solar and wind availability.

The design of a hybrid solar-wind system depends on various factors, including the site location, the load requirements, and the availability of solar and wind resources. The optimal design should consider the specific characteristics of both solar and wind energy and ensure that the system operates efficiently and reliably. The operation of a hybrid solar-wind system is typically controlled by a central controller that manages the power flow between the solar array, wind turbine, and battery bank. The controller also ensures that the system operates within safe and efficient operating limits.

Project Work

Construction: - The choice of material is crucial for the design of blades. since the material we choose should be lighter and able to endure high air pressure. A particular grade of aluminium metal or PVC can be used for this since it is lightweight and resilient to high air pressure. Selecting a blade form is the following crucial step.

The vertical axis highway windmill (VAHW) can use c-type blades. Because of the way it is designed, it can collect the most air pressure and shift the most energy possible from driven wind to rotating mechanical energy.

In vertical axis highway windmills normally have four c-type blades that are placed in the vertical direction. These four blades have normally separated by a 90-degree angle from each other. So that on highways when a vehicle passes the VAHW will rotate in a clockwise direction. The wind turbine blade design has been decided and now the blades must be fixed to build the turbine the arrangement of blades and their rotating directions.

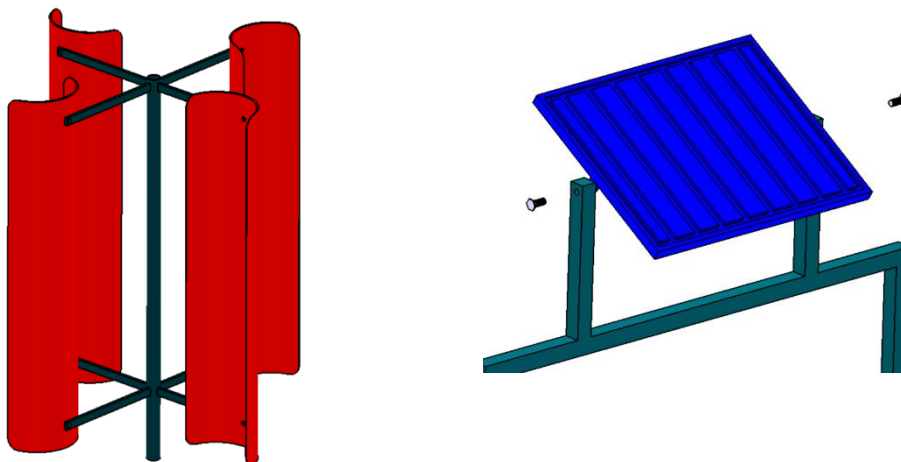

Component Specification: -

COMPONENT	SPECIFICATION	DIMENSIONS
Electric Dynamo	Speed - 60 RPM Torque - 3 Nm Current 0.1 Amp	
Blade Size	PVC Pipe	Length - 45cm Diameter - 10cm
Solar Panel	Power - 5W Current - 1.14 Amp	Length - 29cm Width - 18.5cm Weight - 0.7 kg
Battery	4VDC, Dry Cell, 1.14Amp	

Design Calculation: -

1. Capacity of the battery can be calculated by = $C_{bb} = \frac{Lta_{pp}}{Dd\eta_b V_b} (a)$

L=load (w)

C_{bb} = Capacity of battery

Dd = Discharge

V_b= voltage of the battery

a = Number of days back up

t_{ap} = minimum backup time

2. Total Power Output=Total Area x Solar Irradiance x Conversion Efficiency

Area of Solar Panel(A) = L x b

(A) = 29 x 18.5 = 536.5 sq cm

Solar Irradiance (April for Pune) = 6.97kWh/m²

Conversion Efficiency(For 5 W Solar Panel) = 18%

Total power output = 536.5 x 6.97 x 0.18
= 673.09 Wh

3. Sweep area of the turbine (A) = D x H

D= Diameter

H= Height of turbine

(A)= 45 x 10 = 450 sq cm

4. To calculate Wind Power

$P_{wind} = 0.5 \times \rho \times v^3 \times A$

ρ = Density of air (1.225 kg/m³)

v = wind speed (6m/ sec)

A = Area of turbine

$P_{wind} = 0.5 \times 1.225 \times 6^3 \times 4.5$

$P_{wind} = 16.537 \text{ m/ sec}$

Working:

A device that converts wind energy into electricity is called a wind turbine. The battery charging circuits and then massive utility grids are linked to the generators. In windmills, the air flows across the airfoil area of the blades, creating lift and torque that are both converted into power in the generator. It involves converting wind energy into mechanical energy for the turbine, which is ultimately converted into electricity. The wind turbine's production is erratic and unpredictable since it is reliant on the presence of winds. They may, however, be employed in a big grid alongside traditional generators to lessen the demands placed on those generators while they are generating. The choice is to store power in storage mechanisms like batteries and then discharge it evenly.



Fig.-Working model of Solar and wind turbine Hybrid system

They may, however, be employed in a big grid alongside traditional generators to lessen the demands placed on those generators while they are generating. The choice is to store power in storage mechanisms like batteries and then discharge it evenly.

The form of the aerodynamic airfoil is what gives the blades a lift as the wind flows through them, and this is how it works. The blades move and begin to rotate as a result of the lift created. When the wind direction changes, the yaw unit positions it in the incoming wind direction. The gear train and couplings transport the blades' spinning to the generator, which produces energy. The electricity is subsequently sent across the lines to the grid or the storage batteries.

Benefits of Hybrid Solar-Wind Systems:

- 1) Hybrid solar-wind systems offer improved efficiency over standalone solar or wind systems. This is because the two sources of energy complement each other, with wind turbines producing energy during times when solar panels may not be as effective, and vice versa.
- 2) The reliability of hybrid solar-wind systems is higher than standalone solar or wind systems. This is because the two sources of energy complement each other, reducing the likelihood of power outages or dips in energy output. The system can also store energy in batteries for use during times when neither solar nor wind energy is being generated.
- 3) Hybrid solar-wind systems can offer cost savings over standalone solar or wind systems. This is because the system can be optimized to use the most cost-effective source of energy at any given time, reducing the need for backup systems or energy storage.
- 4) Hybrid solar-wind systems are environmentally friendly and emit no greenhouse gases or other pollutants. By using renewable energy sources, hybrid systems help to reduce the carbon footprint and contribute to a more sustainable future.

