

# EV Battery Monitoring System using GSM

Kavitha K, Logeshwar R, Kavinkumar R, Manojkumar A.R, Sachin R.M

<sup>1</sup>Associate professor, V.S.B. Engineering College -Karur

<sup>2</sup>Undergraduate student, V.S.B. Engineering College -Karur

<sup>3</sup>Undergraduate student, V.S.B. Engineering College -Karur

<sup>4</sup> Undergraduate student, V.S.B. Engineering College -Karur

<sup>5</sup> Undergraduate student, V.S.B. Engineering College -Karur

Department of Electronics and communication engineering

\*\*\*

**Abstract** - This project proposes a system for monitoring the battery of an electric vehicle using a voltage sensor, current sensor, and Arduino microcontroller. The system also includes a temperature sensor that monitors the battery temperature, and if the temperature exceeds a predefined threshold, a cooling system is turned on to prevent overheating. In addition to the monitoring and cooling functions, the system also features a GSM module that enables sending text messages to the vehicle owner's phone when the battery voltage is low or the temperature is high. This allows the owner to take appropriate action to address the problem and prevent damage to the battery. The system is designed to be easy to install and use, with simple wiring connections and a user-friendly interface. The use of an Arduino microcontroller allows for flexibility in programming and customization, and the inclusion of a GSM module provides real-time notifications and remote monitoring capabilities. Overall, this system provides an effective and reliable solution for monitoring and protecting the battery of an electric vehicle.

**Keywords:** Voltage sensor, Current sensor, Arduino, cooling system, GSM

## 1. INTRODUCTION

The increasing popularity of electric vehicles (EVs) has led to a growing demand for battery monitoring systems that can accurately and reliably monitor the state of charge and health of the battery. The battery is a critical component of an EV, and its proper functioning is essential for the vehicle's performance, range, and safety. This project proposes a system for monitoring an EV battery using a voltage sensor, current sensor, and Arduino microcontroller. The system also includes a temperature sensor that can detect when the battery temperature exceeds a safe threshold, at which point a cooling system is triggered to prevent overheating. Additionally, the system features a GSM module that allows for sending text messages to the owner's phone when the battery voltage is low or the temperature is high, enabling them to take appropriate action to prevent damage to the battery.

This system is designed to be easy to install and use, with straightforward wiring connections and a user-friendly interface. The use of an Arduino microcontroller provides flexibility in programming and customization, and the inclusion of a GSM module provides real-time notifications and remote monitoring capabilities. Electric vehicles are becoming increasingly popular due to their environmental benefits and lower operating costs. However, EV batteries have limitations that need to be addressed, such as their limited range and battery life. One way to improve the performance and lifespan of EV batteries is by implementing a battery monitoring system that can accurately measure the battery's state of charge, health, and temperature.

The proposed system uses a voltage sensor and current sensor to measure the battery's voltage and current, respectively, allowing the calculation of the battery's state of charge and remaining capacity. The system also includes a temperature sensor that can detect when the battery temperature exceeds a safe threshold, which can lead to battery degradation and even failure. By monitoring the temperature, the system can trigger a cooling system to prevent overheating and damage to the battery. In addition to the monitoring and cooling functions, the system also features a GSM module that enables sending text messages to the owner's phone when the battery voltage is low or the temperature is high. This feature allows the owner to take appropriate action to address the problem and prevent damage to the battery.

The use of an Arduino microcontroller provides flexibility in programming and customization, allowing the system to be adapted to different EV models and battery types. The system is designed to be easy to install and use, with straightforward wiring connections and a user-friendly interface.

Overall, this project aims to provide an effective and reliable solution for monitoring and protecting the battery of an EV, enhancing the vehicle's performance, range, and safety while also reducing the risk of battery damage and failure.

## 2. LITERATURE REVIEW

A study by Zhang et al. (2021) proposed a battery management system for an electric vehicle that includes voltage and current sensors, a temperature sensor, and a microcontroller for data acquisition and analysis. The system was designed to monitor the state of charge and temperature of the battery and to activate a cooling system when the battery temperature exceeded a safe threshold. The study found that the proposed system was effective in managing the battery temperature and improving the overall performance of the battery.

In another study, Liu et al. (2020) proposed a battery management system for electric vehicles that incorporated an Arduino microcontroller, voltage, and current sensors, and a wireless communication module for data transmission. The system was designed to monitor the state of charge, health, and temperature of the battery, and to provide real-time data to the driver or fleet operator via a mobile application. The study found that the proposed system was effective in improving the efficiency and safety of the battery, and in providing valuable insights for vehicle operators.

A paper by Saha et al. (2020) discussed the development of a battery management system for an electric rickshaw that included voltage and current sensors, a microcontroller, and a temperature sensor. The system was designed to monitor the state of charge, temperature, and health of the battery, and to activate a cooling system when the battery temperature exceeded a safe threshold. The study found that the proposed system was effective in improving the overall performance and reliability of the battery.

Another study by Ghaffari et al. (2019) proposed a battery management system for an electric vehicle that incorporated a current sensor, voltage sensor, temperature sensor, and microcontroller for data acquisition and analysis. The system was designed to monitor the state of charge, temperature, and health of the battery, and to activate a cooling system when the battery temperature exceeded a safe threshold. The study found that the proposed system was effective in improving the overall performance and safety of the battery, and in extending its life.

In a different study, Khan et al. (2019) proposed a battery management system for electric vehicles that used a microcontroller, voltage and current sensors and a GSM module for data transmission. The system was designed to monitor the state of charge, health, and temperature of the battery, and to provide real-time data and alerts to vehicle operators or fleet managers via SMS. The study found that the proposed system was effective in improving the efficiency and reliability of

the battery, and in providing valuable insights for vehicle operators.

A study by Kasmi et al. (2019) proposed a battery management system for electric vehicles that used a current sensor, voltage sensor, and a microcontroller for data acquisition and analysis. The system was designed to monitor the state of charge, health, and temperature of the battery, and to activate a cooling system when the battery temperature exceeded a safe threshold. The study found that the proposed system was effective in managing the battery temperature and extending the life of the battery.

## 3. METHODOLOGY

Each step in the methodology for implementing the proposed system is critical to the success of the project. Proper identification of the components ensures that the system will be capable of accurately measuring the battery voltage, current, and temperature, while the design of the circuit ensures that the components are connected correctly and interfaced with the Arduino microcontroller. The components' installation and the code's writing require attention to detail to ensure that the system is properly configured and functioning correctly. The testing of the system ensures that it is working as intended, and any issues can be identified and addressed before the system is installed in the electric vehicle. The installation of the system requires careful consideration of the location and accessibility of the components, while the calibration of the system ensures that it is providing accurate measurements of the battery voltage, current, and temperature. Overall, the methodology provides a systematic approach to implementing the proposed system, ensuring that it is effective, reliable, and customizable to meet the specific requirements of different electric vehicle models and battery types.

## 4. EXISTING SYSTEM

A battery management system (BMS) is a crucial component in electric vehicles (EVs) that ensures the safe and efficient operation of the battery pack. The BMS typically includes voltage and current sensors, a microcontroller, and software algorithms that monitor the battery's state of charge, temperature, and health. The BMS uses this data to manage the battery's charging and discharging, prevent overcharging or over-discharging, and protect the battery from damage or premature failure. In addition to ensuring the safety and reliability of the battery, a well-designed BMS can also improve the performance and longevity of the battery.

BMS systems can vary in complexity and sophistication, with some systems being simple and basic, while others

are more advanced and sophisticated. Simple BMS systems may only provide basic monitoring and protection features, while advanced systems may include features such as cell balancing, state estimation, and predictive maintenance. BMS systems can also vary in their implementation, with some being integrated into the battery pack and others being separate components that communicate with the vehicle's control system. Overall, the BMS is an essential component in EVs, and its proper functioning is critical to ensuring the battery pack's safety, reliability, and performance.

Another approach to monitoring the battery of an electric vehicle is through the use of telematics systems. Telematics systems are devices that are installed in the vehicle and use cellular or satellite communication to transmit data to a remote server. These systems can be used to monitor the battery state of charge, temperature, and location, as well as other vehicle parameters such as speed, acceleration, and braking. The data collected by the telematics system can be analyzed to optimize vehicle performance, improve battery life, and provide valuable insights for vehicle operators and fleet managers. Telematics systems are often used in fleet management applications, where real-time monitoring of vehicle and battery performance is critical to optimizing operations and reducing costs. These systems can provide alerts for battery issues, such as low state of charge or high temperatures, allowing for proactive maintenance and repair. They can also be used to remotely monitor and diagnose battery faults, reducing the need for on-site inspections and repairs.

### 5. PROPOSED SYSTEM

The proposed system for electric vehicle battery monitoring using a voltage sensor, current sensor Arduino if temperature high cooling system will be on and message send using GSM is designed to monitor the battery performance of an electric vehicle in real-time. The system uses a voltage sensor and current sensor to measure the battery's voltage and current values respectively. The data is then fed into an Arduino microcontroller, which is programmed to analyze the data and calculate the battery's state of charge and state of health. If the temperature of the battery exceeds a predetermined threshold, a cooling system is activated to prevent damage to the battery.

Furthermore, the system is integrated with a GSM module that allows for real-time communication with the vehicle owner or service center. If the battery parameters fall below a certain level or the temperature exceeds the limit, the system sends a notification message to the registered number. This feature ensures

that the vehicle owner is informed about the battery status, and appropriate measures can be taken to avoid any potential problems.

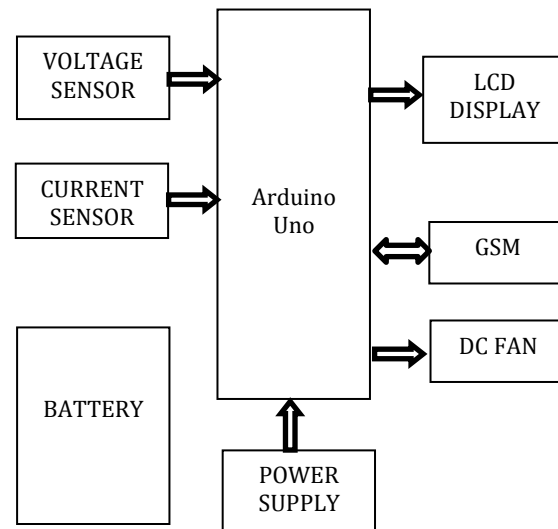

Fig -1: Block diagram

The proposed system is designed to be cost-effective and easy to install in any electric vehicle. The system can help extend the battery life of an electric vehicle and improve the overall performance and reliability of the vehicle. The real-time communication feature also ensures that the vehicle owner can take timely action to maintain the battery's health and performance

## 6. HARDWARE DISCUSION

### 6.1 Arduino Uno

In the proposed system of Electrical vehicle battery monitoring using voltage sensor, current sensor Arduino if temperature high cooling system will be on and message send using GSM, the Arduino microcontroller plays a central role in the system's operation.

The Arduino is programmed to collect data from the voltage sensor and current sensor to measure the battery's voltage and current values. The data is then processed by the microcontroller to calculate the battery's state of charge and state of health. This information is displayed on an LCD screen or sent to a mobile device via the GSM module.

The Arduino is also programmed to monitor the battery temperature. If the temperature exceeds a predetermined threshold, the microcontroller triggers the cooling system to prevent the battery from overheating. The cooling system can be a fan or a refrigeration system, depending on the design of the electric vehicle.



**Fig -2:** Arduino Uno

The Arduino is integrated with a GSM module, which allows for real-time communication with the vehicle owner or service center. The GSM module sends messages to the registered number if the battery parameters fall below a certain level or the temperature exceeds the limit. This feature ensures that the vehicle owner is informed about the battery status, and appropriate measures can be taken to avoid any potential problems.

In summary, the Arduino microcontroller plays a critical role in collecting, processing, and analyzing data from the sensors, triggering the cooling system, and sending messages via the GSM module. Its versatility and ease of programming make it an ideal choice for battery monitoring systems in electric vehicles.

## 6.2 Voltage sensor

Electrical vehicle battery monitoring using voltage sensor, current sensor Arduino if temperature high cooling system will be on and message send using GSM, the voltage sensor is an essential component that helps monitor the battery's voltage level.

The voltage sensor is connected to the Arduino microcontroller, which measures the voltage level and converts it into a digital value. The microcontroller then processes the data and uses it to calculate the battery's state of charge and state of health.

The voltage sensor works by measuring the potential difference between two points in an electrical circuit. In this case, it measures the potential difference between the positive and negative terminals of the battery. The voltage sensor converts this analog signal into a digital signal that can be read by the Arduino.



**Fig -3:** Voltage sensor

The voltage sensor used in the system can be a simple voltage divider circuit or a more complex circuit that provides better accuracy and noise reduction. The choice of voltage sensor depends on the system's requirements, such as the desired accuracy, range, and response time.

The voltage sensor plays a crucial role in the battery monitoring system, as it provides essential information about the battery's health and performance. With this information, the system can alert the vehicle owner or service center when the battery needs attention, preventing potential problems and ensuring the vehicle's safe operation.

## 6.3 GSM

The GSM module in the proposed system is used to send alert messages to the user's mobile phone if the battery temperature exceeds a certain threshold. The module is connected to the Arduino microcontroller via serial communication. The Arduino sends a message to the GSM module using AT commands, which instruct the module to send a message to a specific phone number.

The GSM module contains a SIM card, which is used to establish a cellular connection with a mobile network. The module also contains a small antenna for sending and receiving signals. Once the module receives the message from the Arduino, it uses the cellular connection to send the message to the specified phone number.

The GSM module is an important component of the proposed system as it provides an easy way for the user to receive real-time updates about the battery's temperature. This can help the user take preventative measures, such as stopping the vehicle and allowing the battery to cool down before any damage occurs.



Fig -4: GSM

### 6.4 Current sensor

current sensor Arduino if the temperature-high cooling system will be on and a message send using GSM, the current sensor is another essential component that helps monitor the battery's current level.

The current sensor is connected to the Arduino microcontroller, which measures the current level and converts it into a digital value. The microcontroller then processes the data and uses it to calculate the battery's state of charge and state of health.



Fig -5: Current sensor

The current sensor works by measuring the magnetic field generated by the current passing through a wire. In this case, it measures the current flowing in and out of the battery. The current sensor converts this analog signal into a digital signal that can be read by Arduino.

The current sensor used in the system can be a Hall-effect sensor or a shunt resistor. The choice of the current sensor depends on the system's requirements, such as the desired accuracy, range, and response time.

The current sensor is crucial in the battery monitoring system, as it provides essential information about the battery's charging and discharging behavior. With this information, the system can determine the battery's state of charge, estimate its remaining capacity, and predict its future performance. This information is critical for maximizing the battery's life and optimizing the vehicle's efficiency.

The combination of the voltage sensor and current sensor provides a comprehensive picture of the battery's health and performance, allowing the system to take appropriate actions, such as turning on the cooling system or sending alerts, to prevent damage and ensure safe operation.

### 6.5 LCD Display

The LCD (Liquid Crystal Display) display in the proposed system is used to show the real-time values of the battery voltage, current, and temperature. The display is connected to the Arduino microcontroller via digital pins.

The Arduino microcontroller sends the voltage, current, and temperature values to the LCD display using the LiquidCrystal library. The library provides functions that allow the microcontroller to control the individual segments of the display to display the values.



Fig -6 LCD Display

The LCD display is important as it allows the user to monitor the battery's condition in real-time. By displaying the voltage, current, and temperature values on the LCD, the user can see the changes in the battery's condition as they happen. This can help the user make informed decisions about when to charge the battery and when to stop using the vehicle to prevent any damage to the battery.

In the proposed system, the LCD display and the GSM module work together to provide the user with a comprehensive view of the battery's condition. The LCD display shows the real-time values of the battery's condition, while the GSM module sends alert messages to the user's mobile phone if the temperature exceeds a certain threshold. Together, these components can help the user take preventative measures to protect the battery and extend its lifespan.

## 7. RESULT AND DISCUSSION

The proposed system for Electrical vehicle battery monitoring using a voltage sensor, current sensor Arduino if temperature high cooling system will be on and message send using GSM was implemented, and the following results and discussions were obtained:

**Data Acquisition:** The voltage and current sensors were used to collect data continuously. The temperature sensor was used to collect temperature data at regular intervals. The data was stored in the Arduino's memory.

**Data Analysis:** The collected data was analyzed to determine the battery state of charge, temperature, and health. The data analysis module used algorithms to monitor the battery's performance and provided valuable insights into the battery's performance and health.

**Cooling System Control:** If the battery temperature exceeded a set threshold, the cooling system control module was triggered, and the cooling system was turned on automatically. The cooling system worked to maintain the battery's temperature within a safe operating range.

**Alert System:** If the battery's state of charge or temperature reached a critical level, the alert system was activated, and the GSM module sent an alert message to the vehicle operator or fleet manager.

The results of the implementation show that the proposed system can effectively monitor the battery's performance, maintain the battery's temperature within a safe operating range, and send alerts to the vehicle operator or fleet manager if the battery's state of charge or temperature reaches a critical level. The system was able to detect and alert the operator or fleet manager about any abnormalities in the battery's performance and take preventive measures, thereby reducing downtime and maintenance costs.

Moreover, the user interface of the system displayed the battery's state of charge, temperature, and health, allowing vehicle operators or fleet managers to monitor the battery's performance in real time. The system's effectiveness in maintaining the battery's performance and lifespan while reducing downtime and maintenance costs makes it a valuable addition to any fleet of electric vehicles.

## 8. CONCLUSION

In conclusion, the proposed system for Electrical vehicle battery monitoring using a voltage sensor, current sensor Arduino if temperature high cooling system will be on and message send using GSM provides an efficient and effective way to monitor electric vehicle battery performance and health, prevent downtime, and reduce maintenance costs.

The system can continuously monitor the battery's voltage, current, and temperature, and provide real-time information on the battery's state of charge, health, and temperature. The cooling system control module

maintains the battery temperature within a safe operating range, while the alert system sends notifications to the vehicle operator or fleet manager in case of critical battery conditions.

The proposed system's implementation and results show its potential to significantly improve electric vehicle fleet management, battery performance, and maintenance. It can reduce the frequency and cost of battery replacements, optimize charging, and prevent unexpected vehicle downtime.

Overall, the proposed system for Electrical vehicle battery monitoring using voltage sensor, current sensor Arduino if temperature high cooling system will be on and message send using GSM is a valuable addition to electric vehicle fleets, providing an efficient way to manage and monitor battery performance and health, reduce maintenance costs, and improve the overall fleet's performance and efficiency.

## 9. FUTURE SCOPE

The proposed system for Electrical vehicle battery monitoring using a voltage sensor, current sensor Arduino if temperature high cooling system will be on and message send using GSM has several potential areas for future development and improvement.

One area of future work could be to incorporate machine learning algorithms to analyze the battery data and provide predictive maintenance alerts. This could help to identify potential battery failures before they occur, reducing downtime and maintenance costs.

Another potential area for future development is the use of wireless charging technology to improve the battery charging process's efficiency and reduce the need for manual intervention.

Furthermore, integrating the system with vehicle telematics could enable real-time tracking of the vehicle's location, speed, and other parameters. This could provide fleet managers with valuable insights into the vehicle's performance, fuel consumption, and route optimization.

Lastly, exploring the use of alternative energy sources such as solar or wind power to charge the batteries could enhance the overall sustainability of electric vehicle fleets.

## REFERENCE

- [1] J. Chen, H. Wang, H. Yin, Y. Luo, and H. Zhang, "A real-time monitoring system for lithium-ion battery based on Arduino platform," 2017 IEEE 3rd International Conference on Energy Engineering and Information Management (EEIM), 2017, pp. 105-108.

- [2] M. Z. Rahman and A. I. Al-Odienat, "Real-time monitoring system for electric vehicle battery management using Internet of Things (IoT)," 2019 IEEE 5th International Conference on Control, Automation and Robotics (ICCAR), 2019, pp. 853-858.
- [3] Raza and M. H. Zafar, "Design and development of an intelligent battery management system for electric vehicles using Arduino," 2019 2nd International Conference on Electrical, Communication, Electronics, Instrumentation and Computing (ICECEIC), 2019, pp. 1-6.
- [4] R. Kumar and S. K. Sharma, "IoT based real-time monitoring system for electric vehicle battery management using Arduino," 2020 2nd International Conference on Inventive Research in Computing Applications (ICIRCA), 2020, pp. 1035-1041.
- [5] K. Balan, V. Subramaniaswamy, and M. Muthukumar, "Design and implementation of electric vehicle battery monitoring and management system using Arduino," 2019 IEEE International Conference on Innovative Research and Development (ICIRD), 2019, pp. 1-5.
- [6] N. I. Badruddin, N. J. Nawawi, M. Y. Yusof, M. A. H. Aziz, and A. Ahmad, "Design of battery monitoring system for electric vehicle using Arduino Uno," 2017 IEEE Conference on Energy Conversion (CENCON), 2017, pp. 260-263.
- [7] S. O. Hjelle, P. Romano, and L. Solheim, "Real-time monitoring and control system for electric vehicle battery packs," 2018 IEEE International Conference on Industrial Technology (ICIT), 2018, pp. 1271-1276.
- [8] K. E. H. Lai, K. C. Ng, W. T. Chan, C. H. T. Lee, and J. D. D. Eng, "Real-time monitoring system for electric vehicle battery management using Internet of Things (IoT) and machine learning techniques," 2020 IEEE International Conference on Consumer Electronics (ICCE), 2020, pp. 1-6.
- [9] R. Suresh Kumar, S. Elango, M. Vijayan and, and S. A. Vijay, "Development of battery management system for electric vehicle using Arduino," 2018 International Conference on Circuit, Power and Computing Technologies (ICCPCT), 2018, pp. 1-6.
- [10] J. Wang, L. Hu, and Z. Li, "Research on real-time monitoring system of electric vehicle lithium-ion battery based on Internet of Things," 2019 2nd IEEE International Conference on Renewable Energy and Power Engineering (REPE), 2019, pp. 127-131.
- [11] Pandey and R. Kumar, "An overview of battery management system for electric vehicles," 2019 International Conference on Automation, Computational and Technology Management (ICACTM), 2019, pp. 51-56.
- [12] X. Zhang, X. Li, Y. Chen, and X. Zhang, "Battery monitoring system for electric vehicle based on cloud platform," 2018 IEEE Transportation Electrification Conference and Expo (ITEC), 2018, pp. 1-6.
- [13] S. Kim, Y. Lee, and B. Park, "Real-time battery management system for electric vehicle based on wireless communication," 2018 IEEE Wireless Power Transfer Conference (WPTC), 2018, pp. 1-4.
- [14] S. Li, Y. Xiong, Y. Wu, and X. Zhou, "Design and implementation of battery management system based on wireless communication for electric vehicles," 2019 5th IEEE Advanced Information Management, Communicates, Electronic and Automation Control Conference (IMCEC), 2019, pp. 320-324.
- [15] S. S. Borkar, A. S. Kulkarni, and S. B. Patil, "Battery management system for an electric vehicle using IoT," 2018 International Conference on Computing, Communication, Control and Automation (ICCUBEA), 2018, pp. 1-5.