

DESIGN AND ANALYSIS OF CHASSIS AND 4X4 DRIVETRAIN FOR ALL TERRAIN VEHICLE

Panchal Akshat¹, Mer Ajay Nareshbhai², Ronit Singh Jassal³, Pratham Barot⁴, Noel Edwin Dacruz⁵

¹Student, Gujarat Technological University, Ahmedabad, Gujarat

²Student, Gujarat Technological University, Ahmedabad, Gujarat

³Student, Gujarat Technological University, Ahmedabad, Gujarat

⁴Student, Gujarat Technological University, Ahmedabad, Gujarat

⁵Student, Gujarat Technological University, Ahmedabad, Gujarat

Abstract – The design and analysis of an all-terrain 4x4 vehicle chassis and drivetrain are presented in this study. The chassis, specifically a triangulated space frame, is meticulously designed to meet safety standards, considering impacts and rollovers. Material selection involves AISI 4130 annealed alloy for primary and secondary frame members, optimizing for bending strength and stiffness. Finite Element Analysis (FEA) in ANSYS WORKBENCH is employed for a comprehensive analysis of the roll cage under different loading conditions. The drivetrain focuses on creating a durable and reliable power transmission system to all four wheels, utilizing a Briggs and Stratton OHV Engine and an OEM CVT. Gears are manufactured with precision, and a two-stage reduction gearbox is designed for optimal performance. The drivetrain is analyzed for stress and deformation

Tubular pipes used in the making of the crucial members of the Frame. So, the material used to manufacture the Roll cage was determined in compliance with the standard rules. The rules also specify the minimum clearance of the driver to the roll cage members and these Driver Clearances are validated using a Mannequin consideration in the roll cage design.

Key Words: Chassis, Drivetrain, All-terrain Vehicle, Roll Cage, Finite Element Analysis (FEA), Material Selection, Tubular Frame, ANSYS

Table 1 Vehicle Dimension

Width	57.72 inch
Length	77.51 inch
Height	67.57 inch
Wheel Track	52.00 inch (Front) 49.06 inch (Rear)
Wheel Base	54.00 inch
Ground Clearance	15.00 inch (Front) 14.00 inch (Rear)
Weight (Roll cage)	28.90 kg

1. INTRODUCTION

This collaborative study focuses on the meticulous design and analysis of an all-terrain 4x4 vehicle's chassis and drivetrain. The triangulated space frame, constructed from AISI 4130 annealed alloy, while Finite Element Analysis in ANSYS WORKBENCH verifies structural integrity. The drivetrain integrates a Briggs and Stratton OHV Engine, OEM CVT, and a two-stage reduction gearbox for reliability. Material choices, including EN-353, Aluminum 7075-T6, and Aluminum 6061-T6, emphasize strength and weight reduction. Analyses of the geartrain, differential ring-pinion, and final shaft confirm safety and efficiency.

The ATV design is triangulated space Frame comprised of round tubes. This choice was made in order to maximize cockpit space, as well as increase space on the sides of the car for easier egress and ingress during emergency condition.

2. CHASSIS AND FRAME (ROLLCAGE)

2.1. CRITERIA FOR DESIGN:

The Objective of the design is to create a durable, safe, and easy to maintain vehicle's subsystems with the plus of taking care of the driver safety all the time. The chassis need to be prepared for impacts created in different situations or rollover. It must be strong and durable taking weight distribution always in account for better performance.

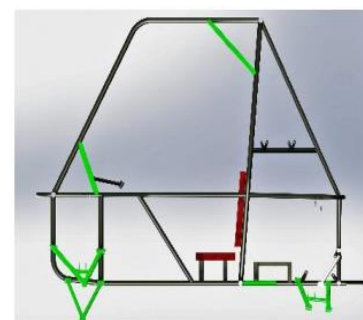

Figure 2.1.1. side view of chassis

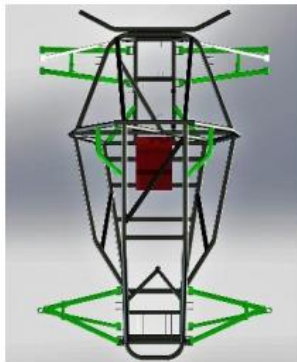

Figure 2.1.2. Top view of chassis

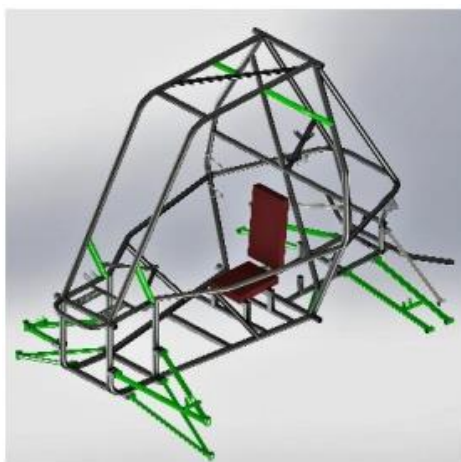

Figure 2.1.3. 3D view of chassis

Ultimate Tensile Strength	813.344 N/mm ²	813.344 N/mm ²
Bending Strength	654.9696 Nm	383.875 Nm
Bending Stiffness	2787.516 N/mm ²	1421.141 N/mm ²

2.3. ANALYSIS

Roll cage design was analysed in ANSYS WORKBENCH 2021 R1 using Finite Element Analysis (FEA) method on 3D pipe element. Entire Roll cage and other components are designed in SOLIDWORKS which are directly imported to ANSYS for Analysis. Roll cage analysis was done under 4G and 3G load for different conditions like Rollover, Side Impact, Rear and Front Impact conditions. Material properties were tested and then it was entered in ANSYS and properties were kept same in all direction. TETRAHEDRAL & HEX DOMINANT mesh method were used, Element size is kept 1D & 3D with Element Quality 0.3 to 1.

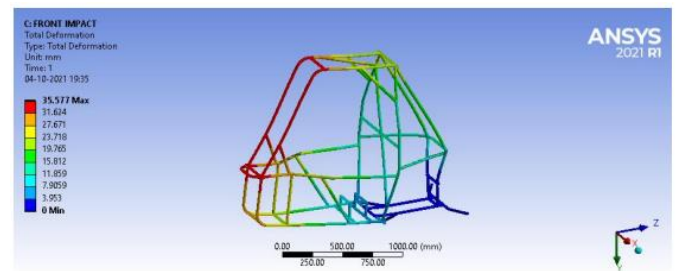

Figure 2.3.1. Rollover analysis of chassis

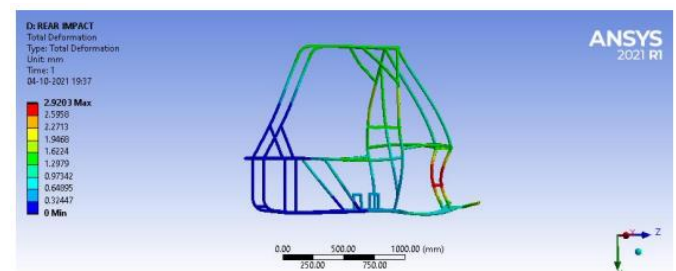

Figure 2.3.2. Side Impact analysis of chassis

2.2. MATERIAL SELECTION:

Primary frame members are fabricated from AISI 4130 annealed alloy 29.2mm OD and 1.65mm Thickness. The selection is based on Bending Strength and Bending Stiffness of the tube profiles and material. AISI 4130 annealed tubes proved Lighter, were more Manufacturable and stronger. Secondary frame members are fabricated from AISI 4130 annealed alloy with 25.4mm OD and 1.25mm Thickness, which meets the secondary member’s strength requirement. This has been done to increase overall strength of the Roll cage.

Table 2. Material data

	Primary members	Secondary members
Material	AISI 4130 annealed	AISI 4130 annealed
Dimensions (OD x thickness)	29.2mm x 1.65mm	25.4mm x 1.25mm
Yield Strength	703.251 N/mm ²	03.251 N/mm ²

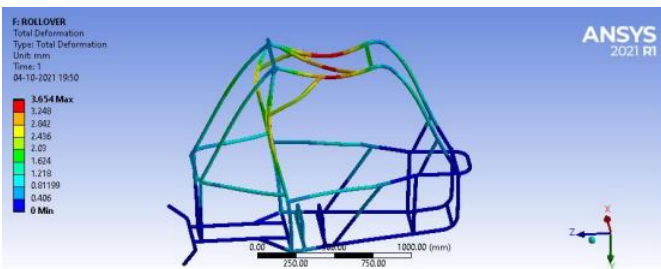

Figure 2.3.3. Rear impact analysis of chassis

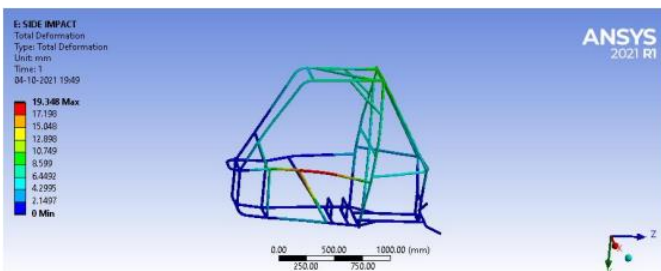

Figure 2.3.4. Front impact analysis of chassis

3. DRIVE TRAIN AND TRANSMISSION

The main Objective is to design a durable and reliable drive line to transmit power to all the 4 wheels of our ATV. This is done by sound engineering practice while manufacturing the gears, custom made shafts (Axle) and Tripod cups which transmits the power to wheels. An OEM CVT is used to obtain different gear ratios with a center-to-center distance of 8.5 inch.

The Drive-Train is Designed around the provided Briggs and Stratton OHV Engine (19L232-0054-G1 Vanguard series), which provides 10HP with a maximum torque of 19.2 Nm. For Gaged 8.5-inch (216mm) Centre to Centre distance CVT belt, skilled and accurate manufacturing is done to mount Engine and Gearbox to ensure the center-to-center distance of the Driver and driven Pulley is maintained for effective power supply.

Gears are manufactured by Hobbing process and the finishing is done by VMC machine. A single propeller shaft is used to transmit power from rear to front and in order to reduce the power losses. The Overall design provides 70.98% gradeability.

Table 3 Powertrain Data

Engine RPM	CVT ratio	Total ratio	Engine Torque (Nm)	Torque on wheels (Nm)	Tractive force
1800	3.9	25.77	18.3	471.68	1690
2400	2.8	18.50	19	351.50	1249
3200	1.7	11.23	18.57	208.54	747
3800	1	5.948	17.9	106.47	381

Gearbox is designed for 2 stage reduction with the help of compound geartrain, which provides a total reduction of 6.6. Material used in manufacturing of gears and compound shaft is EN-353. Material used in Final Output shaft is Aluminium 7075-T6 & material used for gearbox is Aluminium 6061-T6 for better weight reduction and heat dissipation. Overall, FOS of gears is 1.6.

We are using a single propeller shaft for AWD system; we are also using Bevel gears with an FOS of 2.063 to transmit power from rear to front.

Maximum Engine power 10 HP @3800 rpm

Maximum Engine Torque 19.2 Nm @ 2650 rpm

For continues lubrication of gears in gear box we are using 75W90 which has a flash point of 210°C and a Pour Point of 45°C which is adequate for our gearbox.

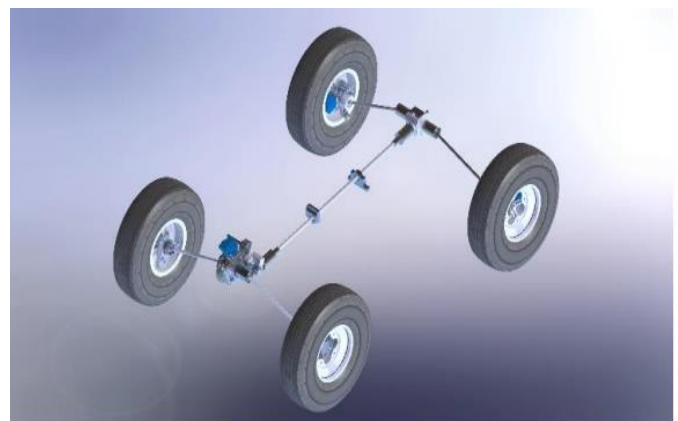

Figure 3.1 Driveline

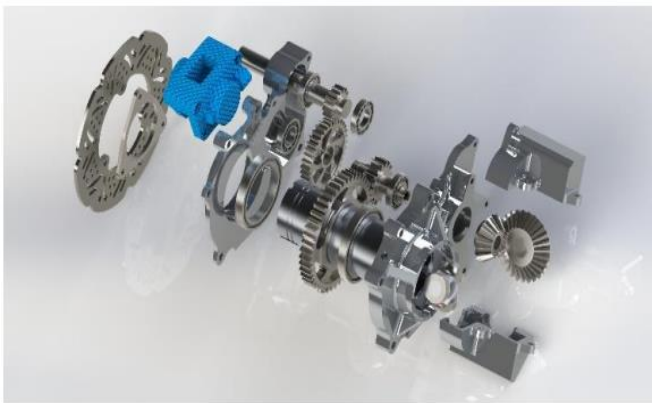

Figure 3.2. Gearbox Exploded View

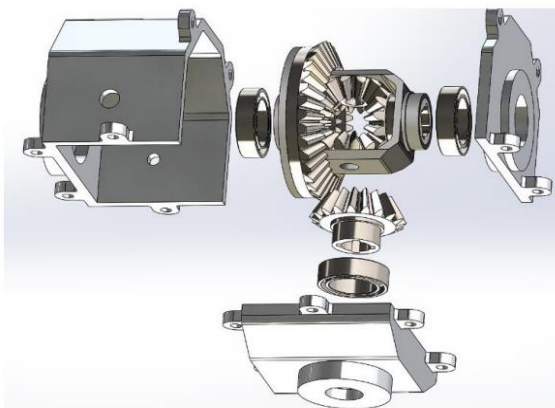

Figure 3.3. Differential exploded view

3.1. ANALYSIS

Geartrain, Differential Ring-Pinion and Final Shaft has been analyzed under extreme tensile stress for any deformation. We deemed the design to be safe and hence finalized the Design.

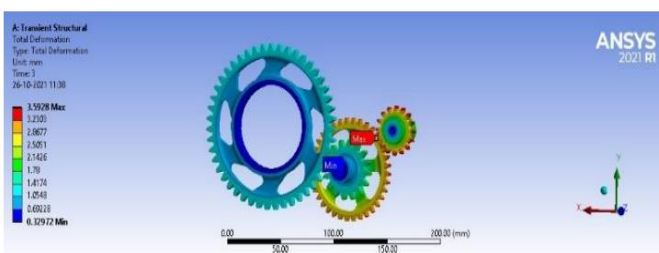

Figure 3.1.1 Geartrain analysis for total deformation

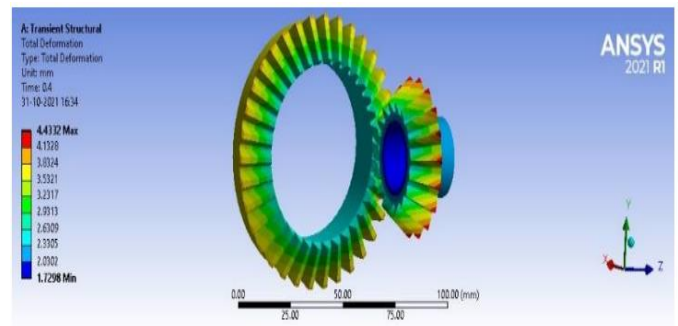

Figure 3.1.2. Differential Ring-Pinion Analysis for Total Deformation

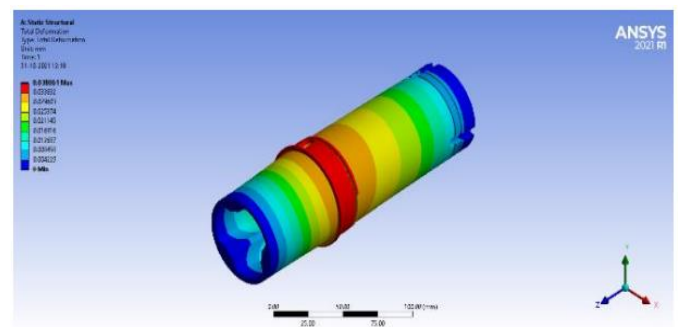

Figure 3.1.3. Output shaft Analysis for Total Deformation

4. CONCLUSIONS

In conclusion, the meticulous design and analysis of the all-terrain 4x4 vehicle's chassis and drivetrain showcase a comprehensive engineering approach, emphasizing durability, safety, and maintenance ease. The triangulated space frame, crafted from AISI 4130 alloy, reflects careful consideration of strength and weight. Finite Element Analysis confirms the structural integrity of the roll cage under varied loads. The powertrain, integrating a Briggs and Stratton OHV Engine, CVT, and well-designed gearbox, prioritizes durability and reliability. Material choices, including EN-353, Aluminum 7075-T6, and Aluminum 6061-T6 for gears and shafts, underscore considerations for strength and weight reduction. Analyses of the geartrain, differential ring-pinion, and final shaft assure safety and efficiency. Overall, the project successfully combines theoretical principles, engineering analyses, and practical considerations, yielding confident conclusions on structural integrity, performance, and safety.

5. REFERENCES

- [1] Gillespie, Thomas D. "Fundamentals of Vehicle Dynamics."
- [2] V.B. Bhandari "Design of Machine Elements"

[3] R.S. Khurmi, "Machine Design"

[4] Bernd Heiring & Metin Ersoy, "Chassis Handbook"

6. BIOGRAPHIES



Mr. Panchal Akshat, Completed Bachelor's Degree in Mechanical Engineering from LJ Institute of Engineering and Technology, Gujarat Technological university



Mr. Mer Ajay Nareshbhai, Completed Bachelor's Degree in Automobile Engineering from LJ Institute of Engineering and Technology, Gujarat Technological university



Mr. Ronit Singh Jassal Completed Bachelor's Degree in Automobile Engineering from LJ Institute of Engineering and Technology, Gujarat Technological university



Mr. Pratham Barot Completed Bachelor's Degree in Automobile Engineering from LJ Institute of Engineering and Technology, Gujarat Technological university

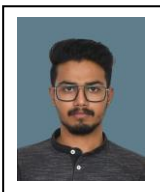

Mr. Noel Edwin Dcruz completed Bachelor's Degree in Automobile Engineering from LJ Institute of Engineering and Technology, Gujarat Technological university