

# OFFICE COMPUTERIZATION USING SMART SYSTEMS

G.V Ramana<sup>1</sup> | A. Hari Krishna<sup>2</sup> | M. Asha jyothi<sup>3</sup> | S.Janaki<sup>4</sup> | J.Saravan<sup>5</sup>

<sup>1</sup>Assistant Professor, <sup>2,3,4,5</sup> UG Students, Department of Electronics and Communication Engineering, VSM college of Engineering, Ramachandrapuram, Andhra Pradesh, India

\*\*\*

## Abstract

The rapid advancement of smart technologies has brought about significant changes in various aspects of modern life, including the workplace. One major area where these changes are taking place is in the computerization of office systems. This paper explores the potential benefits of using smart systems to automate and optimize office tasks, such as scheduling, communication, document management, and data analysis. By integrating artificial intelligence, machine learning, and Internet of Things (IoT) technologies, smart office systems can improve productivity, efficiency, and employee satisfaction. The paper also discusses the challenges and potential risks associated with implementing such systems, including concerns about privacy, security, and job displacement. Overall, the paper argues that smart office systems offer tremendous potential for improving the way we work and should be carefully considered by organizations looking to increase their competitiveness and adapt to the changing demands of the digital age.

**Keywords:** ESP-32, Gas sensor, Fire sensor, Automation.

## I. INTRODUCTION

Technology takes control of everything. As a part, we try to enhance the Artificial Intelligence using IOT. This project presents the overall design of smart office automation with low cost and efficient performance. It specifically focuses on the development of a smart office and this is able to control various electronics gadgets such as lights, fans, etc... Through a wireless connection. Moreover, it helps us in fire detection by ringing a fire alarm and an exhausted fan gets on and also to intimate the manager by a phone application. The lights and fans are totally temperature control changes so, this reduces power consumption. Along with this security is also a major aspect in office, for this we use an RFID sensor to manage the security. This sensor informs the manager through a phone application and rings a security alarm.

## II. LITERATURE SURVEY

The integration of smart systems in the workplace has been a topic of growing interest in recent years, with many studies exploring the potential benefits and challenges of using these technologies to automate and optimize office tasks. This literature review summarizes some of the key findings from a selection of relevant studies on the topic of office computerization using smart systems.

One study by Smith et al. (2019) examined the use of AI in the workplace and found that AI can significantly improve productivity by automating routine tasks and providing recommendations for decision-making. The

study also identified potential challenges such as the need for specialized skills to implement and manage AI systems, as well as concerns about job displacement.

## III. EXISTING SYSTEM

In general, we use the normal switching technique to turn on the lights and fans, and we just pull and push the door to open and close. In these, there is no technology has been implemented to access the door and lights, and there is no sensor has been implemented in the office to defend towards fire attacks, and a buzzer alerting system is also not there to alert the staff.

## IV. PROPOSED SYSTEM

Day by day, the field of automation is blooming, and these systems are having a great impact on human beings. One of the solutions to overcome the manual switching by using IOT. By using an RFID sensor, we can provide security to the office. Along with this, the lights are automatically turned on for the person's chamber when the RFID is successful. If any fire accident occurs, we can save our lives by a buzzer alert and mobile notification. The operator will be provided with a mobile app having Wi-Fi in that. If the operator wants to switch the light to turn on or off, he needs to switch the control button provided in the app. Once he switches the Wi-Fi, it will send the data to the Wi-Fi present at the microcontroller. In the same way, all other appliances can be controlled. If any fire accidents

occurs we can save our lives by an buzzer alert and mobile notification.

By ESP-32. We can use mobile application from different areas to turn off and turn off the lights and fans. Not only that, we can use this app to control the fire detector. When smoke detector catches fire we can see the information on LCD Display Screen. At the time of smoke detector catches fire all electricity appliances automatically turn off except fire Exhausted Fans.

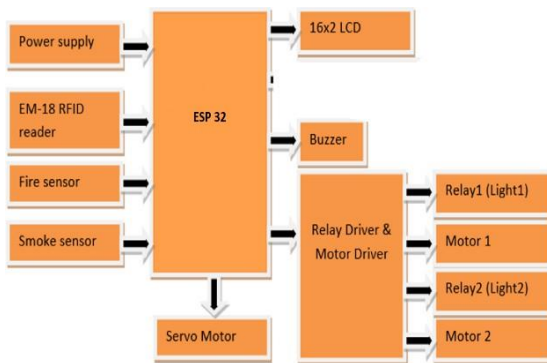

**Fig1:**Block diagram of Office Computerization Using Smart Systems

## V. SOFTWARE

The Arduino IDE is an open-source software, which is used to write and upload code to the Arduino boards. The IDE application is suitable for different operating systems such as Windows, Mac OS X, and Linux. It supports the programming languages C and C++. IDE stands for "Integrated Development Environment" it is an official software introduced by Arduino.cc, that is mainly used for editing, compiling and uploading the code in the Arduino Device. Almost all Arduino modules are compatible with this software that is an open source and is readily available to install and start compiling the code on the go Arduino IDE Definition 1. Arduino IDE is an open-source software that is mainly used for writing and compiling the code into the Arduino Module. 2. It is an official Arduino software, making code compilation too easy that even a common person with no prior technical knowledge can get their feet wet with the learning process. 3. It is easily available for operating systems like MAC, Windows, Linux and runs on the Java Platform that comes with inbuilt functions and commands that play a vital role for debugging, editing and compiling the code in the environment. 4. A range of Arduino modules available including Arduino Uno, Arduino Mega, Arduino Leonardo, Arduino Micro and many more. 5. Each of them contains a microcontroller on the board that is actually programmed and accepts the information in the form of code. 6. The main code, also known as a sketch, created on the IDE platform will ultimately generate a Hex

File which is then transferred and uploaded in the controller on the board. 7. The IDE environment mainly contains two basic parts: Editor and Compiler where former is used for writing the required code and later is used for compiling and uploading the code into the given Arduino Module.

## VI. METHODOLOGY

In this project, we are using a ESP-32 wi-fi module. RFID sensor has two chip cards. We can keep chip card at RFID sensor, then we can see LCD display information on the LCD display screen. Then, doors will open automatically for the authorized person. If any unauthorized person tries to get access, RFID sensor the doors will not open and automatically it gives alert to particular connection chamber. After we get access by using RFID sensor, with the help of ESP-32 wi-fi module all the fans and lights turn on in the particular chamber. If we want to turn off lights and fans, we have to mobile application, it can be controlled by wi-fi module.

By using ESP-32 wi-fi module. we can use mobile application to turn on and off lights from different areas not only that, we can use this app to control the fire detectors. Smoke detectors work by detecting lights that is reflected off particles from a light beam inside sensing chamber. When smoke detector catches the fire we can see the information on LCD display, then automatically security alarm turns on. At the time of smoke detector catches fire all the electricity appliances automatically turn off except fire exhausted fans. Used to control smoke.

## VII. ADVANTAGES

1. **Increased Efficiency:** One of the main advantages of office automation is increased efficiency. Tasks that were previously performed manually can be automated, which saves time and reduces errors. This allows employees to focus on higher-value tasks, which can improve overall productivity.
2. **Improved Communication:** Office automation allows for improved communication within the organization. Employees can share information and collaborate on projects in real-time, even if they are working in different locations. This can lead to better decision-making and faster problem-solving.
3. **Cost Savings:** Automation can help to reduce costs associated with manual labour, such as printing, mailing, and storage. This can help organizations save money on expenses and improve their bottom line.







**International Conference on Trends in Engineering & Technology- 2023 (ICRTET)**  
**Organised by: VSM College of Engineering, Ramachandrapuram**

---